



# TSUKATANI

STEEL CUTTING RULE  
TOOLS & EQUIPMENT



Mother Company

**TSUKATANI HAMONO MFG. CO., LTD.**

5-30 Kusunecho, Yao City, Osaka 581-0814 Japan  
Trading Department  
Phone : +81-72-996-8774 Fax : +81-72-996-7715  
e-mail : [ex-import@tsukatani-hamono.co.jp](mailto:ex-import@tsukatani-hamono.co.jp)  
<https://www.tsukatani-hamono.co.jp>



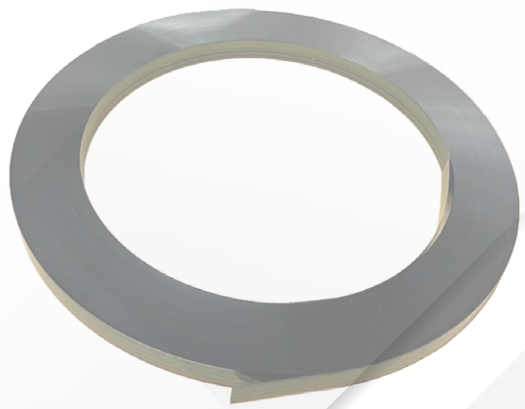

# We are pioneers of Cutting Rules.

We have been developing TSUKATANI's unique technologies and providing high quality products in the ever-growing fields of "Cutting". We will have such technologies incorporated faster in our products by reliable engineers so as to create more comfortable manufacturing environment for our customers with the corporate vision "All technologies belong to the benefit of all customers", aiming to provide TSUKATANI's own optimal steel cutting rules on which no one's ever worked.

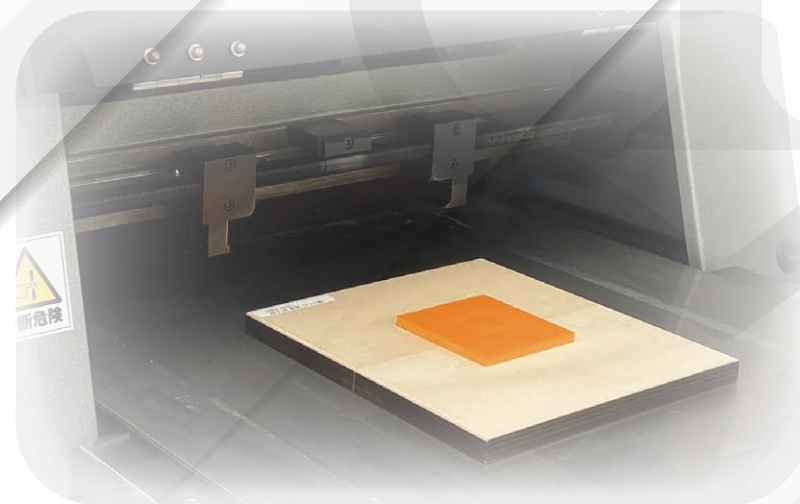

# TSUKATANI

## INDEX

### STEEL CUTTING RULE

Hardness .....	4
Edge profile .....	5
super G type .....	6
ISDB / super WG type .....	7
Steel cutting rule .....	8
MG knife / PL blade .....	10
Coated rule / Zipper rule .....	11
New wave rule / Double Deckle .....	12
Cut Crease .....	13
Cut & Round Crease / Perforation rule .....	14
Micro perforation rule .....	15
Rotary die rule (hard) .....	16
Rotary die rule (soft) .....	17
Label rule .....	18
High rule .....	20
Stainless steel rule / Composer knife .....	22
Doctor Blade / Bog Knife .....	23
Crease rule .....	24
Decowave .....	27
Punch .....	28
RDC-FB type .....	32
Specifications & Technical information .....	33
Packaging & Conversion tables .....	34

### TOOLS & EQUIPMENT

CT type .....	35
EP type .....	37
BD type .....	38

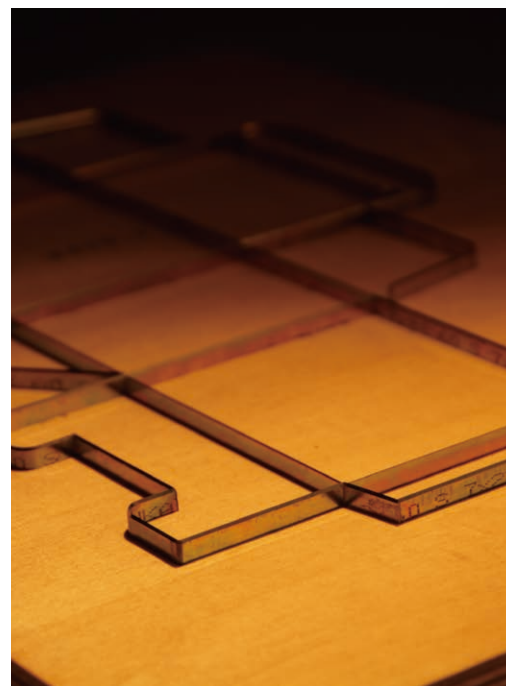

## Hardness

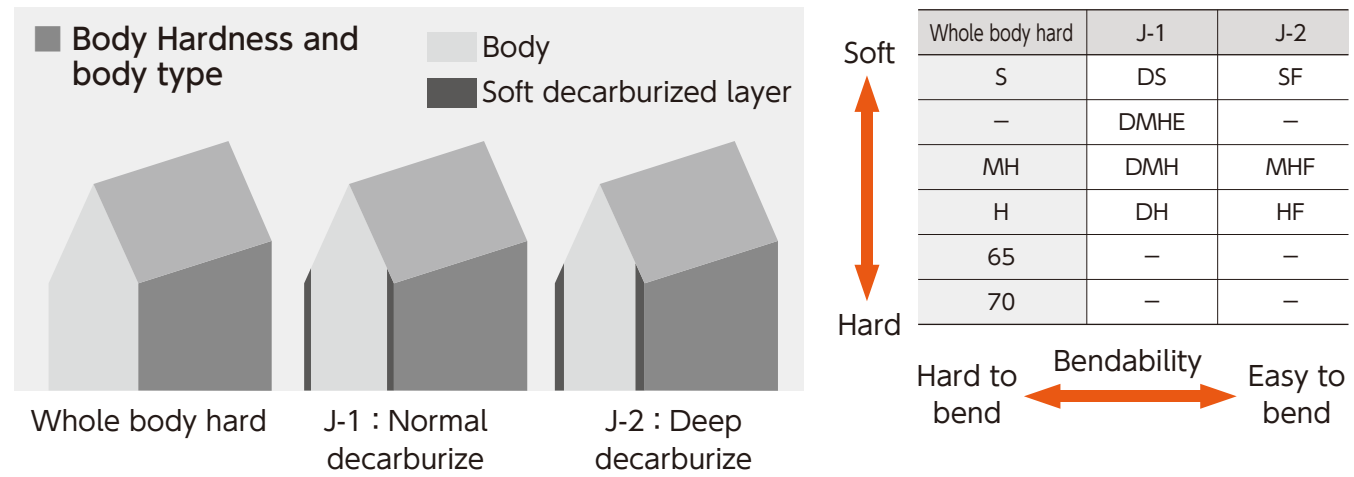
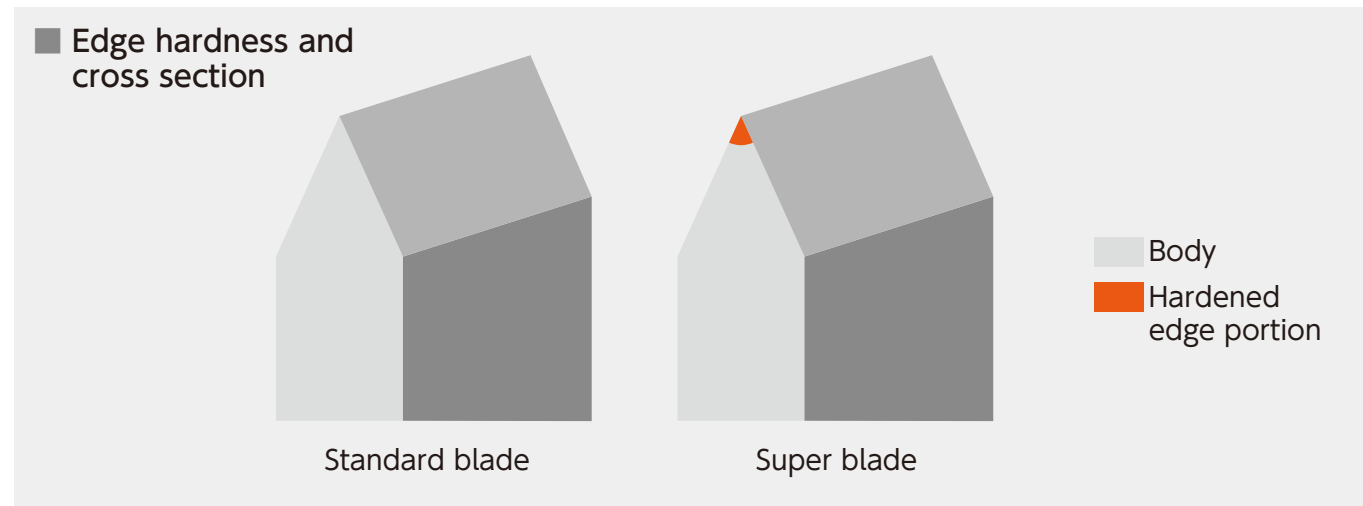

## Conversion tables

HS	40	45	50	55	60	65	70	75	80
HV	280	320	360	400	450	490	550	620	670
HRC	27.4	32.4	36.7	40.8	45.5	48.4	52.6	56.2	59.2

## Edge type



## Edge profile

[Thickness:0.71mm]

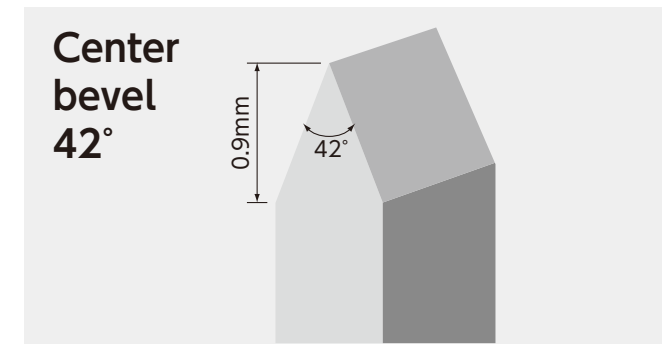

Features :  
The most standard profile of 42 degrees center bevel.

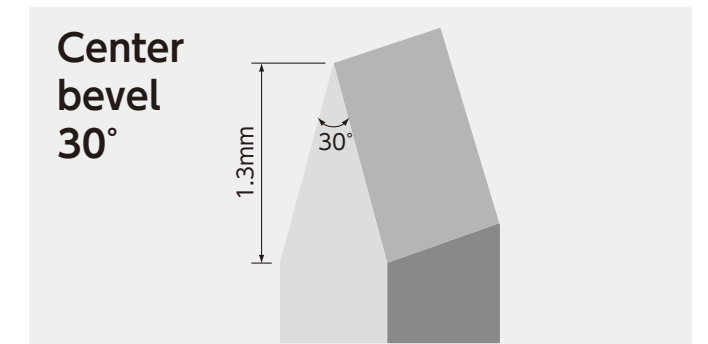

Features :  
The profile of 30 degrees center bevel suitable for cutting special films, tacky films, and other materials required sharpness.

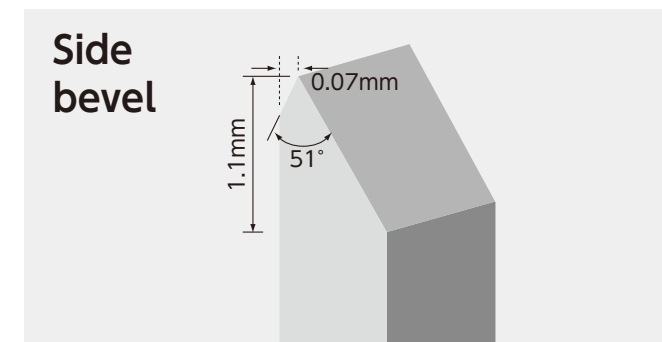

Features :  
The profile of 51 degrees side bevel suitable for packing, and gaskets, and cutting the outer form directly.

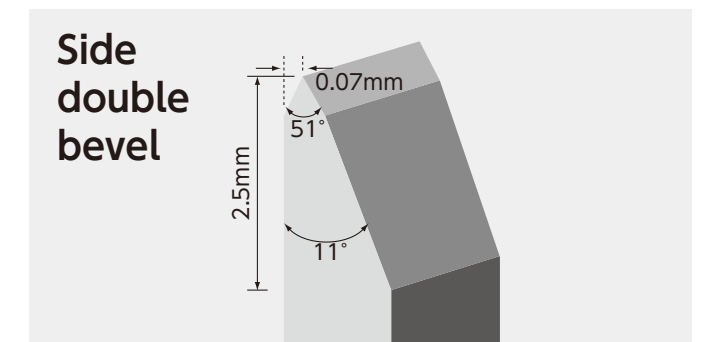

Features :  
The profile of 51 degrees side double bevel suitable for cutting the outer form directly and deburring, similar to side bevel.

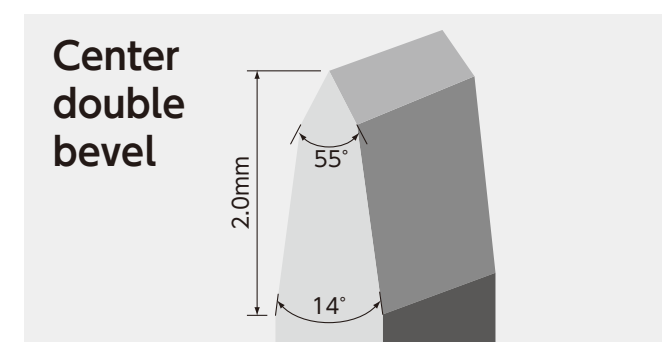

Features :  
The profile of 55 degrees center double bevel suitable for cutting thick multilayered papers and other materials requiring durability.

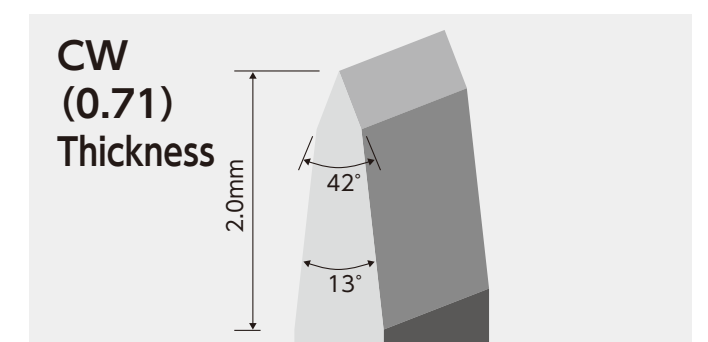

Features :  
The profile of 42 degrees center double bevel suitable for cutting thick multilayered papers and other materials requiring durability.



# Quality control

that is  
**super G type**

The super G type is our original product. TSUKATANI mirror-like finishing to provide an exceedingly sharp edge, thus eliminating damage to objects to be cut and reducing cutting force. The mirror-like finishing has effect in providing smooth and beautiful cut surface and also preventing printed material from peeling or detaching, which can not be obtained by grinding process only.

## super G type : Mirror-like finished portion

### Label rule

Thickness(mm)	Code	Hardness(Hs)		Height(mm)	Profile
		Body	Edge		
0.45	DS-80	50	80	8.00	CB42°
				9.50	CB42°
				12.00	CB42°

### Steel cutting rule

Thickness(mm)	Code	Hardness(Hs)		Height(mm)	Profile
		Body	Edge		
0.71	DS-70	46	70	23.60 23.80	CB30°
				23.60 23.80	CB42°
	DH-80	60	80	23.60 23.80	CB30°
				23.60 23.80	CB42°
	MHF-80	53	80	23.60 23.80	CB30°
23.60 23.80				CB42°	
DMH-80B	53	76	23.60 23.80	ISDB36°G-G	
DMH-80B	53	76	23.60 23.80	ISDB30°G	

- The standard length is 915mm. Special request to make 1220mm, coil products, or lengths.
- Different heights and hardness are available.

## ISDB

It prevents the bent round corner and the cutting rule from leaning down and easy to make die flat adjustment.

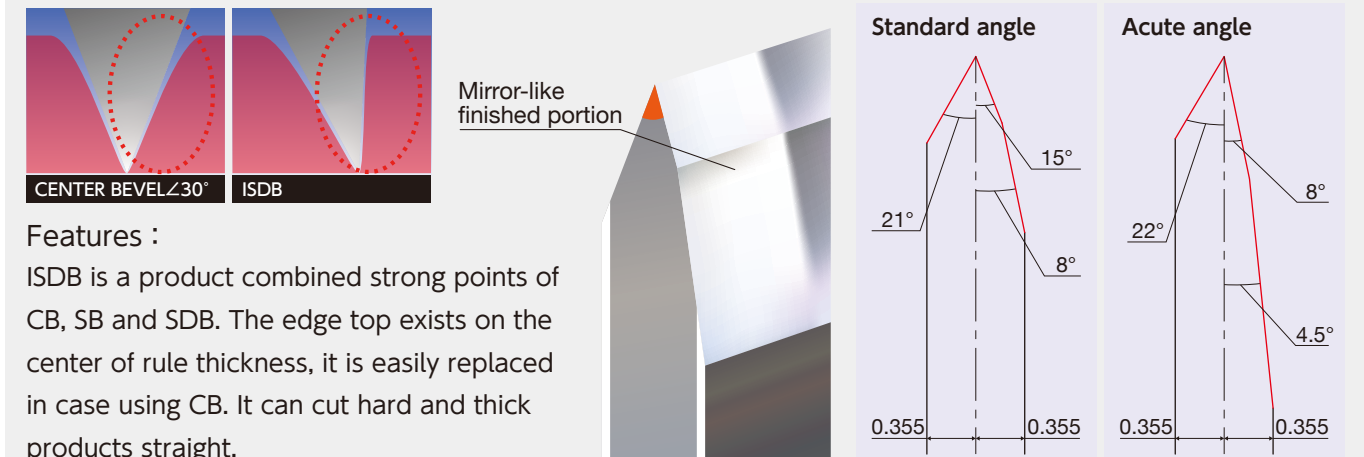

### Features :

ISDB is a product combined strong points of CB, SB and SDB. The edge top exists on the center of rule thickness, it is easily replaced in case using CB. It can cut hard and thick products straight.

## super WG type : Prevent paper dust

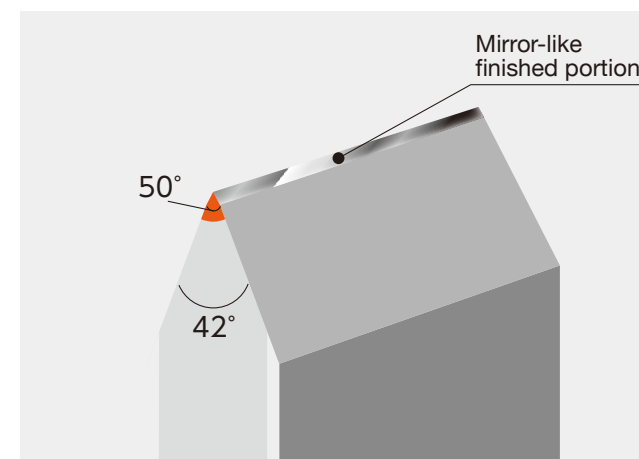

The super WG type has been developed for the prevention of paper particulates. We apply mirror-like finishing to the first bevel out of the double bevel rule profile to provide an optimal wear status for the edge without degrading the sharpness of the edge, thus making it possible to prevent paper particulates from being produced from paper containers or package.

Thickness(mm)	Code	Hardness(Hs)		Height(mm)	Profile
		Body	Edge		
0.71	HF-80B	60	76	23.60 23.80	CDB50°
					NEW WAVE2P
0.90	DMH-75	53	75	23.60 23.80	CDB50°
					NEW WAVE2P
1.07	DMH-75	53	75	23.60 23.80	CDB60°
					NEW WAVE2P

- The standard length is 915mm. Special request to make 1220mm, coil products, or lengths.
- Available to make new wave rules.(3P,4P)



# Steel cutting rule

## Center bevel

R

### Super blade

Thickness (mm)	Code	Hardness (Hs)		Height (mm)	Profile
		Body	Edge		
0.45	S-70	47	70	23.60 23.80	CB42°
	H-80	60	80	23.60 23.80	CB42°
	DS-70	46	70	23.50	CB42°
	23.60 23.80			CB30° CB42°	
0.71	S-70	42	70	23.60 23.80	CB42°
	MH-80	53	80	23.60 23.80	CB42°
	H-80	60	80	23.60 23.80	CB30° CB42°
	65-80	65	80	23.60 23.80	CB42°
	DS-70	46	70	22.40	CB42°
				23.30	CB42°
				23.40	CB42°
				23.44	CB42°
				23.50	CB42°
				23.60 23.80	CB30° CB42°
	DS-80	46	80	23.60 23.80	CB42°
	DH-70	60	70	23.60 23.80	CB42°
	DH-80B	60	76	23.60 23.80	CB42°
	DH-80	60	80	23.60 23.80	CB30° CB42°
	SF-70	46	70	23.44	CB42°
23.50				CB42°	
23.60 23.80				CB42°	
MHF-80B	53	76	23.60 23.80	CB42°	
HF-80	60	80	23.60 23.80	CB42°	
0.90	S-70	42	70	23.60 23.80	CB42°
	S-80	42	80	23.60 23.80	CB42°
	DMH-70	53	70	23.60 23.80	CB42°
	DH-70	60	70	23.60 23.80	CB42°
1.00	S-70	47	70	23.60 23.80	CB42°

## Center double bevel

R

### Super blade

Thickness (mm)	Code	Hardness (Hs)		Height (mm)	Profile
		Body	Edge		
0.71	S-70	42	70	23.60 23.80	CW42° CDB55°/52°
	65-80	65	80	23.60 23.80	CW42° CDB55°/52°
	DH-80B	60	76	23.60 23.80	CW42° CDB55°/52°
	DH-80	60	80	23.60 23.80	CW42° CDB55°/52°
	HF-80	60	80	23.60 23.80	CW42° CDB55°/52°
0.90	S-70	42	70	23.60 23.80	CDB55°
	DMH-70	53	70	23.60 23.80	CDB55°

● The standard length is 915mm. Special request to make 1220mm, coil products, or lengths.

## Side bevel

R

### Super blade

Thickness (mm)	Code	Hardness (Hs)		Height (mm)	Profile
		Body	Edge		
0.71	S-70	42	70	23.60 23.80	SB51°
	H-80	60	80	23.60 23.80	SB51°

● The standard length is 915mm. Special request to make 1220mm, coil products, or lengths.

## Side double bevel

R

### Super blade

Thickness (mm)	Code	Hardness (Hs)		Height (mm)	Profile
		Body	Edge		
0.71	S-70	42	70	23.60 23.80	SDB51°
	H-80	60	80	23.60 23.80	SDB51°
	65-80	65	80	23.60 23.80	SDB51°

● The standard length is 915mm. Special request to make 1220mm, coil products, or lengths.

## MG knife

R

Features : The MG knife is steel cutting rule with a special back profile easy to fit to the back plate so that die cutting is enabled in a balanced manner. This type of steel cutting rule is effective in shortening time to remedy uneven cutting.

Thickness (mm)	Code	Hardness (Hs)		Height (mm)	
		Body	Edge		
0.71	D4075	40	75	23.65	23.85
	DS-70	46	70	23.65	23.85
	SF-80	46	80	23.65	23.85

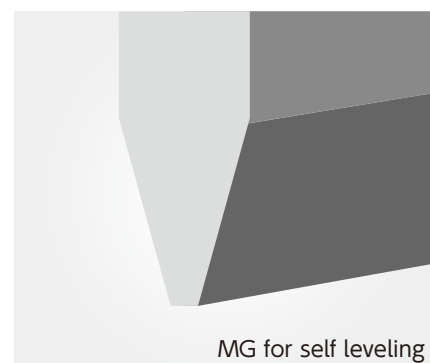

- The standard length is 915mm. Special request to make 1220mm, coil products, or lengths.

## PL blade

R

Features : The PL blade is a steel cutting rule developed to die cut thin plywood and jigsaw puzzles. Since the PL Blade has triple long bevel profile with a long edge portion, it is able to cut thick materials such as Styrofoam and cushions without causing cut resistance.

Thickness (mm)	Code	Hardness (Hs)		Height (mm)		Profile
		Body	Edge			
0.71	H	60		23.60	23.80	CTB(4.2)
	S-70	42	70	23.60	23.80	CTB(4.2)
	H-80	60	80	23.60	23.80	CTB(4.2)
1.00	DMH-70	53	70	23.60	23.80	CDB(4.2)

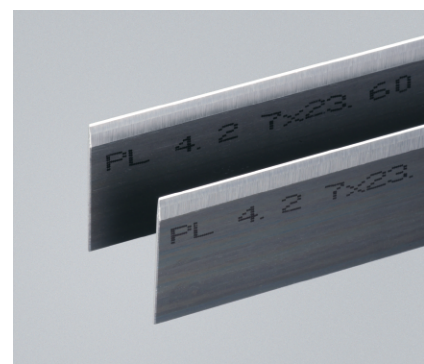

- The standard length is 915mm. Special request to make 1220mm, coil products, or lengths.
- Inside the ( ) stands for the length of the bevel.

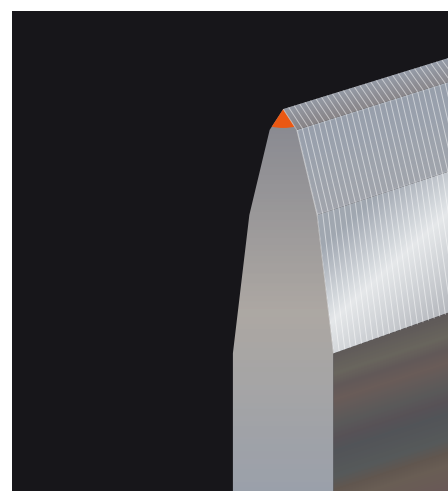

### PL blade

#### Purposes

#### Cut materials :

- \* Paper + laminated film
- \* Paper packaging + laminated film
- \* Card board + cardboard with film
- \* Cigarette boxes + laminated film
- \* Pharmaceutical boxes + laminated film
- \* Corrugated boxes board
- \* Leather
- \* Plastic: PP, PVC, PET, foam
- \* Gaskets
- \* Electronics: Film

## Coated rule : Anti-adhesive

Features : Each coating has anti-adhesive coating layer at edge. It can reduce cutting defect caused by adhesion. TK coating rule is not coated 0.1mm~0.7mm from the tip.

Thickness (mm)	Code	Hardness (Hs)		Height (mm)		Profile
		Body	Edge			
0.71	F Coating	46	70	23.60	23.80	CB42° Fluorine coating
	TX Coating	46	70	23.60	23.80	CB42° Fluorine coating
	TK Coating	46	70	23.60	23.80	CB42° Silicone coating (tip sheltered)
	B-BLAST	46	70	23.60	23.80	CB42° Silicone coating

- F coating and TX coating is 915mm, TK coating and B-BLAST is 1200mm.



For low adhesive films	For display films	For thick adhesive materials	For high adhesive films	Ultimate durability
<b>F coating</b>	<b>TX coating</b>	<b>TK coating</b>	<b>B-BLAST</b>	<b>Titanium</b>
Material: Fluorine Film thickness: 10µm Tip: Coated Non-adhesive: ✓ Cleaning: Using thinner ✓	Material: Fluorine Film thickness: 1µm Tip: Coated Non-adhesive: ✓ Cleaning: Using thinner ×	Material: Silicon Film thickness: 10µm Tip: Non-coated Non-adhesive: ✓ Cleaning: Using thinner ✓	Material: Silicon Film thickness: 10µm Tip: Coated Non-adhesive: ✓ Cleaning: Using thinner ✓	Material: Tin Film thickness: 1µm~3µm Tip: Coated For extra longevity Cleaning: Using thinner ✓

## Zipper rule

R

Thickness (mm)	Code	Hardness (Hs)		Height (mm)		Profile
		Body	Edge			
0.71	2×7	42		23.60	23.80	CB42°
	3×4	42		23.60	23.80	CB42°
	3×5	42		23.60	23.80	CB42°
	3×6	42		23.60	23.80	CB42°
	3×7	42		23.60	23.80	CB42°
	3×8	42		23.60	23.80	CB42°
	3×9	42		23.60	23.80	CB42°
	3×10	42		23.60	23.80	CB42°

- All the product is metal plated.
- To be able to make the tip-hardened products.

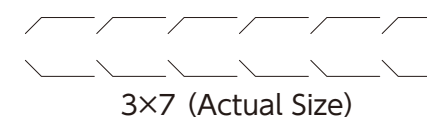
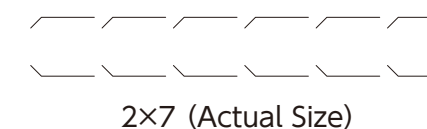
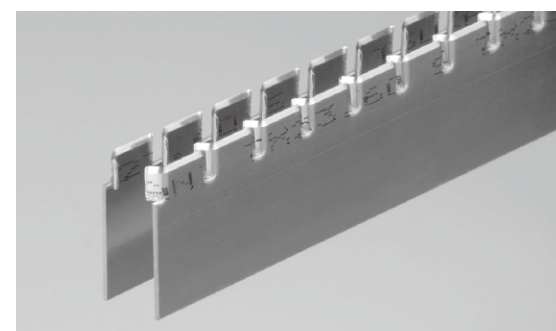



## New wave rule

R

Thickness (mm)	Code	Hardness (Hs)		Pitch	Height (mm)		Profile
		Body	Edge				
0.71	S-70	42	70	1P	23.60	23.80	CB42°
				2P	23.60	23.80	CB42°
				3P	23.60	23.80	CB42°
				4P	23.60	23.80	CB42°
0.90	S-70	42	70	1P	23.60	23.80	CB42°
				2P	23.60	23.80	CB42°
				3P	23.60	23.80	CB42°
				4P	23.60	23.80	CB42°
1.07	S-70	43	70	1P	23.60	23.80	CB50°
				2P	23.60	23.80	CB50°
				3P	23.60	23.80	CB50°
				4P	23.60	23.80	CB50°

● The standard length is 915mm.

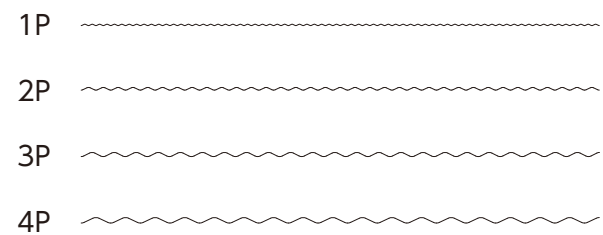

(Actual tip wavyline : Thickness 0.71mm)

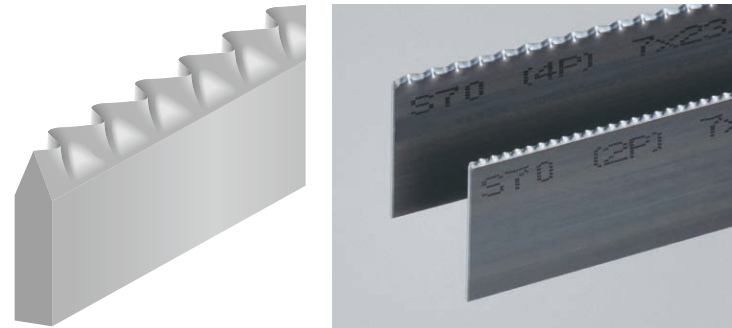

## Double Deckle : Wave process for cutting corrugated boards

Feature: Random wave edges reduce injury on finger from corrugated boards after cutting.



Standard Wave



Double Deckle

**Benefit:**  
For better creasing in corrugated and fiber boards.  
Edge hardened wave rules offer perfect bendability and high wear resistance.  
The wave prevents injury.

● Can be offered from 1 coil.

Pitch

Random wave allows smoother and safer cut surface



**FREE**  
license free  
There is no right of usage.  
Can be used freely and safely.

## Cut Crease

R

Thickness (mm)	Cut×Crease (mm)	Blade height (mm)		Crease height (mm)			Hardness (Hs)	Profile
0.71	2×2	23.60	23.80	23.00	23.10	23.30	60	CB42°
	3×3	23.60	23.80	23.00	23.10	23.30	60	CB42°
	4×4	23.60	23.80	23.00	23.10	23.30	60	CB42°
	5×5	23.60	23.80	23.00	23.10	23.30	60	CB42°
	5×10	23.60	23.80	23.00	23.10	23.30	60	CB42°
	6×6	23.60	23.80	23.00	23.10	23.30	60	CB42°
	7×7	23.60	23.80	23.00	23.10	23.30	60	CB42°
	8×8	23.60	23.80	23.00	23.10	23.30	60	CB42°
	9×9	23.60	23.80	23.00	23.10	23.30	60	CB42°
	10×5	23.60	23.80	23.00	23.10	23.30	60	CB42°
	10×10	23.60	23.80	23.00	23.10	23.30	60	CB42°
	10×15	23.60	23.80	23.00	23.10	23.30	60	CB42°
	10×20	23.60	23.80	23.00	23.10	23.30	60	CB42°
	10×30	23.60	23.80	23.00	23.10	23.30	60	CB42°
	15×15	23.60	23.80	23.00	23.10	23.30	60	CB42°
	15×20	23.60	23.80	23.00	23.10	23.30	60	CB42°
0.90	5×5	23.60	23.80	23.00	23.10	23.30	53	CB42°
	5×10	23.60	23.80	23.00	23.10	23.30	53	CB42°
	10×10	23.60	23.80	23.00	23.10	23.30	53	CB42°
	10×15	23.60	23.80	23.00	23.10	23.30	53	CB42°
	10×20	23.60	23.80	23.00	23.10	23.30	53	CB42°
	10×30	23.60	23.80	23.00	23.10	23.30	53	CB42°
	20×20	23.60	23.80	23.00	23.10	23.30	53	CB42°
1.00	5×5	23.60	23.80	23.00	23.10	23.30	47	CB42°
	10×10	23.60	23.80	23.00	23.10	23.30	47	CB42°
	10×15	23.60	23.80	23.00	23.10	23.30	47	CB42°
	10×20	23.60	23.80	23.00	23.10	23.30	47	CB42°
	15×15	23.60	23.80	23.00	23.10	23.30	47	CB42°
1.07	5×5	23.60	23.80	23.00	23.10	23.30	43	CB50°
	10×10	23.60	23.80	23.00	23.10	23.30	43	CB50°
	10×15	23.60	23.80	23.00	23.10	23.30	43	CB50°
	10×20	23.60	23.80	23.00	23.10	23.30	43	CB50°
	15×15	23.60	23.80	23.00	23.10	23.30	43	CB50°
1.42	5×5	23.60	23.80		22.83	23.10	45	CB50°
	5×10	23.60	23.80		22.83	23.10	45	CB50°
	10×10	23.60	23.80	22.60	22.83	23.10	45	CB50°
	10×15	23.60	23.80	22.60	22.83	23.10	45	CB50°
	10×20	23.60	23.80	22.60	22.83	23.10	45	CB50°
	15×15	23.60	23.80	22.60	22.83	23.10	45	CB50°
	15×20	23.60	23.80	22.60	22.83	23.10	45	CB50°
	20×20	23.60	23.80	22.60	22.83	23.10	45	CB50°
	20×30	23.60	23.80	22.60	22.83	23.10	45	CB50°

● The standard length is 915mm.

● To be able to make the edge hardened products and coil products.



## Cut & Round Crease R

Can be processed from any cut and crease rules.

Features :

- Longitudinal crack hardly occurs.
- Work efficiency at production site is improved.
- Beautiful assembling.
- Available without changing use conditions.
- Applicable to every combination cutting/creasing.

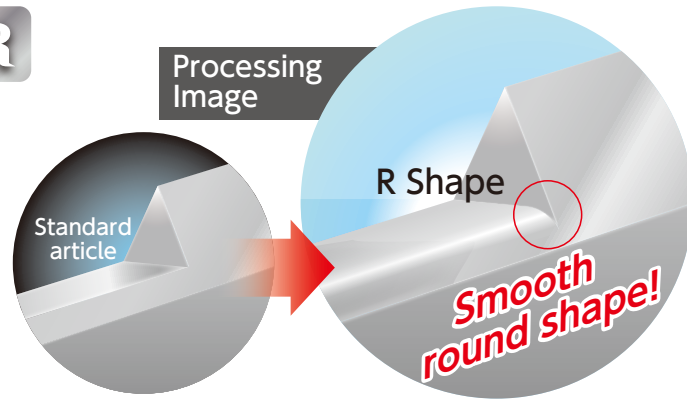

## Perforation rule R

Profile of perforation rule (Actual Size : Thickness 0.71mm)

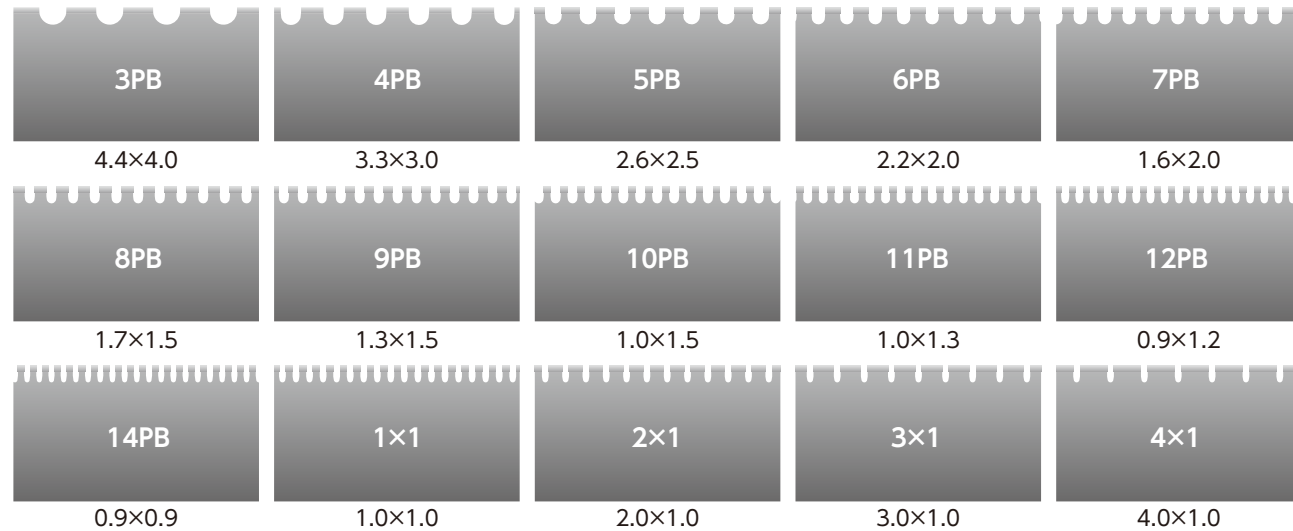

Thickness(mm)	Code	Cut(mm)	Uncut(mm)	Height(mm)			Hardness(Hs)	Profile
0.45	7P3B	2.8	0.8	23.00	23.50	23.80	47	CB42°
	14PB	0.9	0.9		23.50	23.80	47	CB42°
	2x1	2.0	1.0		23.50	23.80	47	CB42°
	3x1	3.0	1.0	23.00	23.50	23.80	47	CB42°
0.71	3PB	4.4	4.0	23.10	23.60	23.80	60	CB42°
	4PB	3.3	3.0	23.10	23.60	23.80	60	CB42°
	5PB	2.6	2.5	23.10	23.60	23.80	60	CB42°
	6PB	2.2	2.0	23.10	23.60	23.80	60	CB42°
	7PB	1.6	2.0	23.10	23.60	23.80	60	CB42°
	8PB	1.7	1.5	23.10	23.60	23.80	60	CB42°
	9PB	1.3	1.5	23.10	23.60	23.80	60	CB42°
	10PB	1.0	1.5	23.10	23.60	23.80	60	CB42°
	11PB	1.0	1.3		23.60	23.80	60	CB42°
	12PB	0.9	1.2		23.60	23.80	60	CB42°
14PB	0.9	0.9		23.60	23.80	60	CB42°	

Thickness(mm)	Code	Cut(mm)	Uncut(mm)	Height(mm)			Hardness(Hs)	Profile
0.71	1x1	1.0	1.0	23.60	23.80	60	CB42°	
	1x2	1.0	2.0	23.60	23.80	60	CB42°	
	2x1	2.0	1.0	23.60	23.80	60	CB42°	
	2x1.5	2.0	1.5	23.60	23.80	60	CB42°	
	2x2	2.0	2.0	23.60	23.80	60	CB42°	
	2x3	2.0	3.0	23.60	23.80	60	CB42°	
	2.5x1.5	2.5	1.5	23.60	23.80	60	CB42°	
	2.5x2	2.5	2.0	23.60	23.80	60	CB42°	
	2.5x2.5	2.5	2.5	23.60	23.80	60	CB42°	
	3x1	3.0	1.0	23.10	23.60	23.80	60	CB42°
	3x1.5	3.0	1.5	23.60	23.80	60	CB42°	
	3x2	3.0	2.0	23.60	23.80	60	CB42°	
	3x3	3.0	3.0	23.60	23.80	60	CB42°	
	4x1	4.0	1.0	23.60	23.80	60	CB42°	
	4x2	4.0	2.0	23.60	23.80	60	CB42°	
4x4	4.0	4.0	23.60	23.80	60	CB42°		
5x1	5.0	1.0	23.60	23.80	60	CB42°		
5x2	5.0	2.0	23.60	23.80	60	CB42°		
0.90	2x2	2.0	2.0	23.60	23.80	53	CB42°	
	3x3	3.0	3.0	23.10	23.60	23.80	53	CB42°
	4x4	4.0	4.0	23.10	23.60	23.80	53	CB42°
	5x5	5.0	5.0	23.10	23.60	23.80	53	CB42°
	3PB	4.4	4.0	23.10	23.60	23.80	53	CB42°
	4PB	3.3	3.0	23.10	23.60	23.80	53	CB42°
	6PB	2.2	2.0	23.10	23.60	23.80	53	CB42°
7PB	1.6	2.0	23.10	23.60	23.80	53	CB42°	

- The standard length is 915mm. (Thickness of 0.45 is 610mm standard)
- To be able to make the edge hardened products and coil products.

## Micro perforation rule R

Thickness(mm)	Code	Cut(mm)	Uncut(mm)	Height(mm)			Hardness(Hs)	Profile
0.71	0.20x0.15	0.20	0.15	23.60	23.80	60	CB42°	
	0.28x0.23	0.28	0.23	23.60	23.80	60	CB42°	
	0.35x0.15	0.35	0.15	23.60	23.80	60	CB42°	
	0.35x0.23	0.35	0.23	23.60	23.80	60	CB42°	

- The standard length is 915mm.
- For instance: 72TPI(0.20x0.15), 50TPI(0.28x0.23 or 0.35x0.15)





## Rotary die rule (hard)

R

### Center bevel 50°

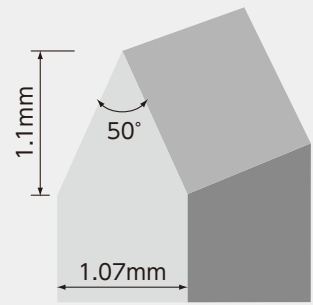

#### Features :

The Rotary die rules (hard) are steel cutting rules of the flat / rotary type used to die cut cardboards. Since the edge comes into direct contact with the stainless steel sheet and the anvil cylinder, these rules have an obtuse-angled center bevel profile. In order to respond to high-speed work, high-frequency processing is applied to the edge.

Thickness(mm)	Code	Hardness(Hs)		Height(mm)	Length and Profile
		Body	Edge		
1.07	S-70	43	70	23.60 23.80	CB50°
					CB50° with notch
	DMH-70	53	70	23.60 23.80	CB50°
					CB50° with notch
					405φ
1.20	DMH-70	53	70	23.60 23.80	CB50°
					CB50° with notch
1.42	S-70	45	70	23.60 23.80	CB50°
					CB50° with notch

- Length : Standard 915mm, Coil 70m 50m.
- 15mm comb and endless process are available.



## Rotary die rule (soft)

R

### Center bevel saw

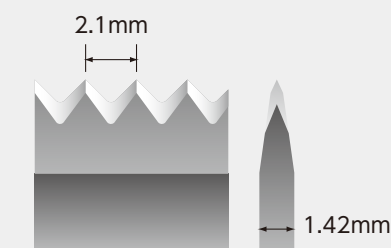

### Side bevel saw

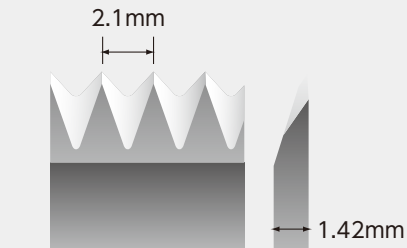

#### Features :

The Rotary die rules (soft) are steel cutting rules of the rotary type used to die cut cardboards. The center bevel saws and side bevel saws are fabricated to a profile by grinding so that the saws will fit to urethane anvil mounted to the anvil cylinder. The high-frequency processing is standardized for the Rotary die rules (soft) .

#### Center bevel saw

Thickness(mm)	Code	Hardness(Hs)		Height(mm)			Length and Profile
		Body	Edge				
1.42	R-01	45	70	23.80	24.10	24.40	Flat
	R-02	45	70	23.80	24.10	24.40	Flat with notch
	R-03	45	70	23.80	24.10	24.40	255φ~405φ
	R-04	45	70			24.40	480φ~720φ

#### Side bevel saw

Thickness(mm)	Code	Hardness(Hs)		Height(mm)			Length and Profile
		Body	Edge				
1.42	R-01	45	70	23.80	24.10	24.40	Flat
	R-02	45	70	23.80	24.10	24.40	Flat with notch
	R-03	45	70	23.80	24.10	24.40	255φ~405φ
	R-04	45	70			24.10 24.40	480φ~720φ

- Length : R-01·R-02 1000mm / R-03·R-04 Endless 30mCoils.
- Notch depth 7mm & 13mm. (R-02·R-03·R-04)



# Label rule

## Center level 42°

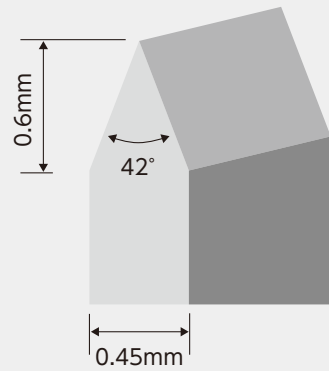

## Side double bevel

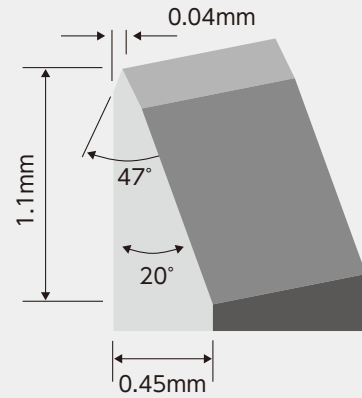

### Features :

The Label rules are steel cutting rules used to cut adhesive sheets such as labels, double-sided adhesive tapes and adhesion parts. Since these rules should be bent into complex profiles, they have thin thickness and different height to adapt to machine specifications. The ground edge is available to cutting adhesive sheets with a resin coating applied without encountering resistance.

## Label center bevel

### Super blade

Thickness(mm)	Height (mm)	Code	Hardness(Hs)		Profile
			Body	Edge	
0.45	7.0	DS-70	50	70	CB42°
	8.0	DS-70	50	70	CB42°
		DS-80	50	80	CB42°
		DMH-70	53	70	CB42°
	DMH-80	53	80	CB42°	
	9.5	DS-70	50	70	CB42°
12.0	DS-70	50	70	CB42°	

### Standard blade

Thickness(mm)	Height (mm)	Code	Hardness(Hs)		Profile
			Body	Edge	
0.45	5.2	DMH	53		CB42°
	7.0	DMH	53		CB42°
	8.0	DMH	53		CB42°
	9.5	DMH	53		CB42°
	12.0	DMH	53		CB42°

● The standard length is 915mm.

## Label side double bevel

Thickness(mm)	Height (mm)	Code	Hardness(Hs)		Profile
			Body	Edge	
0.45	8.0	S-70	50	70	SDB47°
	12.0	S-70	50	70	SDB47°

● The standard length is 915mm.

## Label perforation rule

Thickness(mm)	Height (mm)	Code	Cut(mm)	Uncut(mm)	Hardness (Hs)	Profile
0.45	8.0	1×1	1.0	1.0	53	CB42°
		2×1	2.0	1.0	53	CB42°
		3×1	3.0	1.0	53	CB42°
		4×1	4.0	1.0	53	CB42°
	12.0	1×1	1.0	1.0	53	CB42°
		2×1	2.0	1.0	53	CB42°

● The standard length is 915mm.

## Label micro perforation rule

Thickness(mm)	Height (mm)	Code	Cut(mm)	Uncut(mm)	Hardness (Hs)	Profile
0.45	8.0	0.20×0.15	0.20	0.15	53	CB42°
		0.28×0.23	0.28	0.23	53	CB42°
		0.35×0.15	0.35	0.15	53	CB42°
	12.0	0.20×0.15	0.20	0.15	53	CB42°
		0.28×0.23	0.28	0.23	53	CB42°
		0.35×0.15	0.35	0.15	53	CB42°

● The standard length is 915mm.

● 72TPI : 0.20×0.15, 50TPI : 0.35×0.15

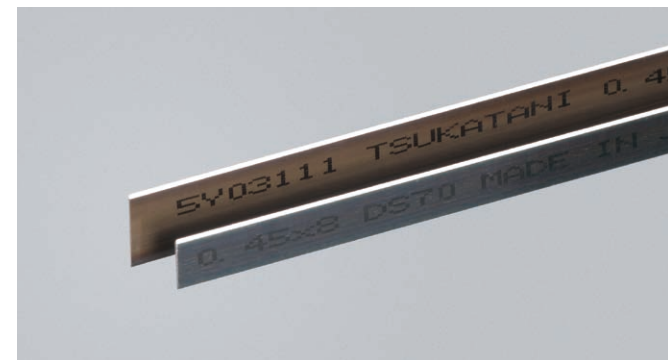

Label rule



Label perforation rule



# High rule

## Features :

The High rules are steel cutting rules used to die cut plastic molded products having substantial depth and height such as food trays and plastic containers as well as honeycomb boards having substantial thickness. These rules are excellent in both bending workability and elastic strength that apply the features of ground edge and bainite treatment.

### Center bevel (0.71mm) 42°

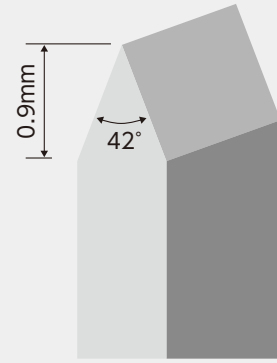

Center bevel with 42 degrees profile.

### CW (1.0mm) Thickness

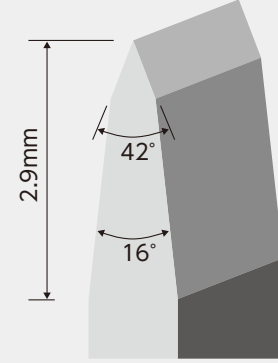

The most standard profile with 42 degrees center double bevel.

### Side double bevel (1.0mm)

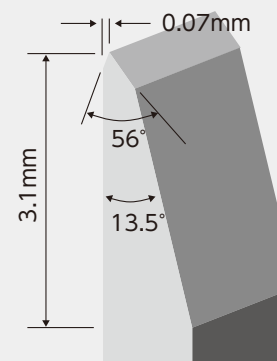

Side double bevel with 56 degrees profile. Suitable for trays and cutting the the outer form.

### Center double bevel (1.5mm)

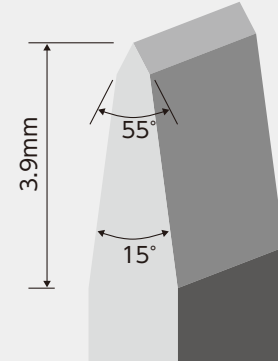

Center double bevel with 55 degrees profile.

## High rule center bevel



Thickness (mm)	Height (mm)	Code	Hardness (Hs)		Profile
			Body	Edge	
0.71	29.00	S-70	50	70	CB42°
		S-80	50	80	CB42°
		H-80	60	80	CB42°
	30.00	S-70	50	70	CB42°
		H-80	60	80	CB42°
		S-70	50	70	CB42°
32.00	S-70	50	70	CB42°	
	H-80	60	80	CB42°	

● The standard length is 2000mm. Special request to make 1000mm, coil products, or lengths.

## High rule CW/CDB



Thickness (mm)	Height (mm)	Code	Hardness (Hs)		Profile
			Body	Edge	
0.71	29.00	S-70	50	70	CW42°
	30.00	S-70	50	70	CW42°
		S-80	50	80	CW42°
		DH-80	55	80	CW42°
	32.00	S-70	50	70	CW42°
	35.00	S-80	50	80	CW42°
39.00	S-80	50	80	CW42°	
1.00	29.00	S-80	45	80	CW42°
	30.00	S-80	45	80	CW42°
	32.00	S-80	45	80	CW42°
	35.00	S-80	45	80	CW42°
	40.00	S-80	45	80	CW42°
	45.00	S-80	45	80	CW42°
	50.00	S-80	45	80	CW42°
	55.00	S-80	45	80	CW42°
	60.00	S-80	45	80	CW42°
	65.00	S-80	47	80	CW42°
	70.00	S-80	47	80	CW42°
	75.00	S-80	47	80	CW42°
	80.00	S-80	47	80	CW42°
	90.00	S-80	47	80	CW42°
100.00	S-80	47	80	CW42°	
1.05	29~60	48-80	48	80	CW42°
	29~60	52-80	52	80	CW42°
	29~60	60-80	60	80	CW42°
1.50	23.60	DH-80	52	80	CDB55°
	29.00	DH-80	52	80	CDB55°
	32.00	DH-80	52	80	CDB55°
	35.00	DH-80	52	80	CDB55°

● The standard length is 2000mm. Special request to make 1000mm, coil products, or lengths.

## High rule SDB

R

Thickness (mm)	Height (mm)	Code	Hardness (Hs)		Profile
			Body	Edge	
1.00	30.00	S-80	45	80	SDB
	35.00	S-80	45	80	SDB
	40.00	S-80	45	80	SDB
	45.00	S-80	45	80	SDB
	50.00	S-80	45	80	SDB
	55.00	S-80	45	80	SDB
	60.00	S-80	45	80	SDB
1.50	23.60	DH-80	52	80	SDB
	32.00	DH-80	52	80	SDB

● The standard length is 2000mm. Special request to make 1000mm, coil products, or lengths.

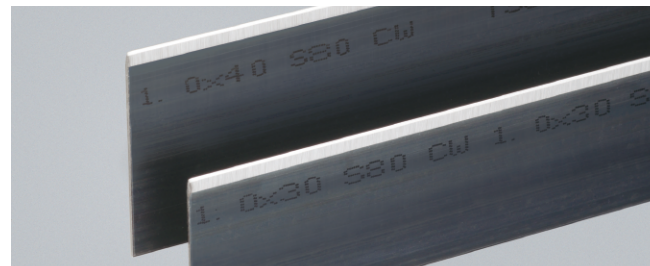

## Stainless steel rule

R

Thickness (mm)	Code	Hardness (Hs)		Height (mm)	Profile
		Body	Edge		
0.71	Silver cutter	54		23.60	CB42°
	Super silver cutter	30	70	23.60	CB42°

● The standard length is 915mm.

## Composer knife

Thickness (mm)	Straight (mm)	Height (mm)	Body hardness	Edge Angle	Profile
0.71	up to 2,700	23.00~26.00	70	30°, 36°	SDB
1.20	up to 3,300	24.10~26.00	70	CDB∠29°, CDB∠30°, CDB∠40°, SDB∠42°	

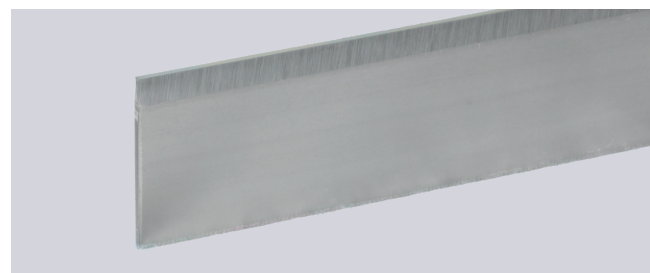

## Doctor Blade

Thickness (mm)	Straight (mm)	Height (mm)	Body hardness	Edge Angle	Profile
0.71	up to 1,345	39.00	70	21°	ASB



## Bog Knife

Thickness (mm)	Straight (mm)	Height (mm)	Code	Cut & Uncut	Body hardness	Tip	Depth of perfo (mm)	Profile
1.00	up to 3,420	25.00	2.0	1.0 & 1.0	70	•Flat edge •Flat edge perfo	0.5 1.0 1.2 1.3 1.5	•Flat edge •Single flat edge perfo •Both flat edge perfo
	up to 3,420	25.00	2.7	1.5 & 1.2	70			
	up to 3,420	25.00	3.0	1.8 & 1.2	70			
	up to 3,420	25.00	3.0	2.0 & 1.0	70			
	up to 3,420	25.00	3.1	2.2 & 0.9	70			
	up to 3,420	25.00	3.3	2.0 & 1.3	70			
	up to 3,420	25.00	3.8	2.3 & 1.5	70			
	up to 3,420	25.00	3.8	2.5 & 1.3	70			
	up to 3,420	25.00	3.8	2.6 & 1.2	70			
	up to 3,420	25.00	3.8	2.8 & 1.0	70			
	up to 3,420	25.00	5.0	4.0 & 1.0	70			
	up to 3,420	25.00	6.6	6.1 & 0.5	70			
up to 3,420	25.00	10.0	7.6 & 2.4	70				

● Can cut to be desired length and possible to make coil products with 100m long.

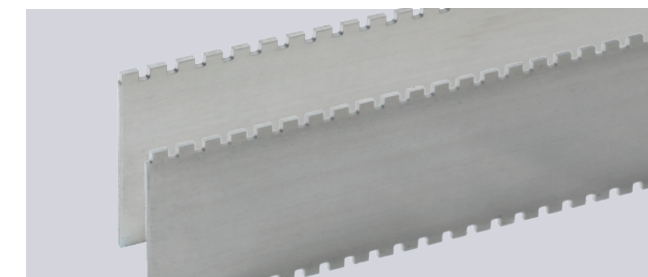



# Crease rule

## Features :

The Crease rules are used to crease cutting sheets. The creasing profile, height and thickness are chosen taking into account the material, thickness, and batch size of cutting sheets. The choice of crease rules is an important component in manufacturing packages. In this connection, we have established high quality standards to ensure flexible response to supply of suitable crease rules to customers.

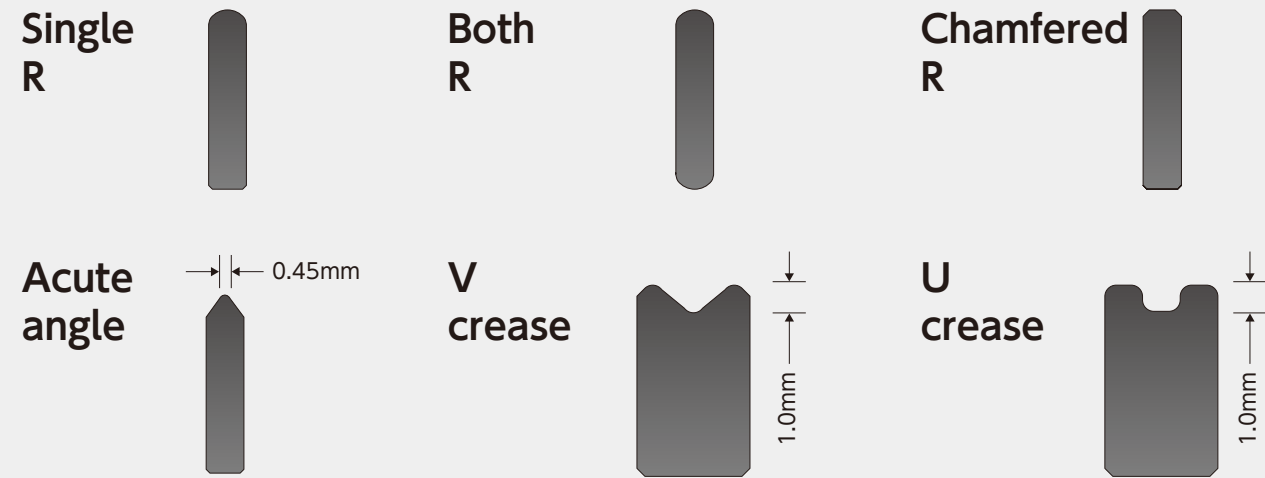

## Mushroom crease rule

Features : The width of crease and the body is different. It was made to unify the width of lazer cutting ditches.

Code	Thickness (mm)		Height (mm)	Profile
	Body	Edge		
0.71-1.0	0.71	1.0	22.80	Single R
			23.10	Single R
0.71-1.4	0.71	1.4	22.80	Single R
			23.10	Single R
			23.20	Single R
0.9-1.4	0.9	1.4	22.80	Single R

● The standard length is 915mm.

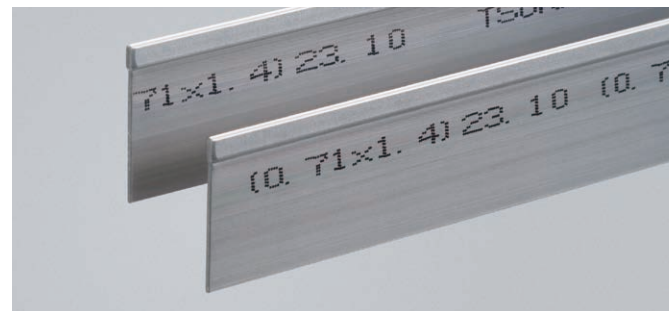

## Hardened crease rule

Thickness (mm)	Height (mm)	Hardness (Hs)	Profile		
0.71	22.60~23.80	60	Single R	Both R	Acute angle
0.9	23.00	60	Single R		
	23.10	60	Single R		

● The standard length is 915mm. Special request to make 1220mm, coil products, or lengths.

## Non-hardened crease rule

Thickness (mm)	Height (mm)	Profile			
0.71	22.60	Single R	Both R		
	22.83	Single R	Both R		
	22.90	Single R			
	23.00	Single R	Both R		
	23.10	Single R	Both R		
	23.20	Single R	Both R		
	23.30	Single R			
	23.50	Single R			
0.9	22.50	Single R			
	22.60	Single R			
	22.83	Single R	Both R		
	22.90	Single R	Both R		
	23.00	Single R	Both R		
	23.10	Single R	Both R		
1.0	22.60	Single R			
	22.83	Single R	Both R		
	22.90	Single R			
	23.00	Single R	Both R		
	23.10	Single R	Both R		
1.2	22.60	Single R			
	22.83	Single R			
	23.00	Single R			
	23.10	Single R			



## Non-hardened crease rule

Thickness (mm)	Height (mm)	Profile			
1.4	21.00	Single R			
	21.60	Single R			
	22.00	Single R			
	22.30	Single R			
	22.50	Single R			
	22.60	Single R	Both R	Chamfered R	
	22.70	Single R			
	22.83	Single R		Chamfered R	
	22.90	Single R		Chamfered R	
	23.00	Single R			
23.10	Single R	Both R			
1.5	21.60	Single R	Single R with notch		
	22.00	Single R	Single R with notch		
	22.30	Single R	Single R with notch		
	22.60	Single R	Single R with notch	Both R	
	22.83	Single R			
	23.00	Single R			
23.10	Single R				
1.8	22.50	Single R			
	22.60	Single R			
	22.83	Single R			
	23.00	Single R			
	23.10	Single R			
2.0	21.60	Single R	Single R with notch		
	22.00	Single R			
	22.30	Single R			
	22.50	Single R			
	22.60	Single R	Single R with notch		
	22.83	Single R			
	22.90	Single R			
	23.00	Single R			
23.10	Single R				
3.0	21.00	Single R	Single R with notch		
	21.60	Single R	Single R with notch		
	22.00	Single R	Single R with notch	U crease	
	22.30	Single R			V crease
	22.50	Single R			
	22.60	Single R			
	22.85	Single R	Single R with notch	U crease	V crease
	23.00	Single R	Single R with notch	U crease	V crease
	23.10	Single R		U crease	V crease

- The standard length is 915mm. Special request to make 1220mm, coil products, or lengths. (coil products can be up to 1.5mm thick)
- The standard depth of the notch is 15mm.
- To be able to make unichrome plating and non-neutralized plating etc.

## Decowave

Features : Perfect Creasing rule for corrugated board

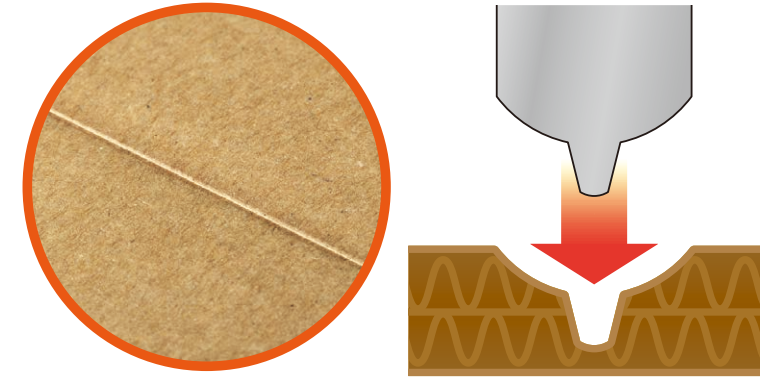

### Benefit:

The wavy shoulder is gripping the cardboard, holding with precise positioning for the crease to be formed accurately and prevents the material cracking due to reducing the pressure placed on the surface. This action creates a smooth crease line, 180° fold is achieved without any problem.

Thickness (mm)	Hardness (Hs)		Height (mm)	Profile
	Body	Edge		
1.8	DD		20.6~23.1	800
				800 with notch
				RC-03 800
2.0	DD		20.6~23.1	800
				800 with notch
				RC-03 800

- The standard length is 800mm



**FREE**  
license free

There is no right of usage.  
Can be used freely and safely.

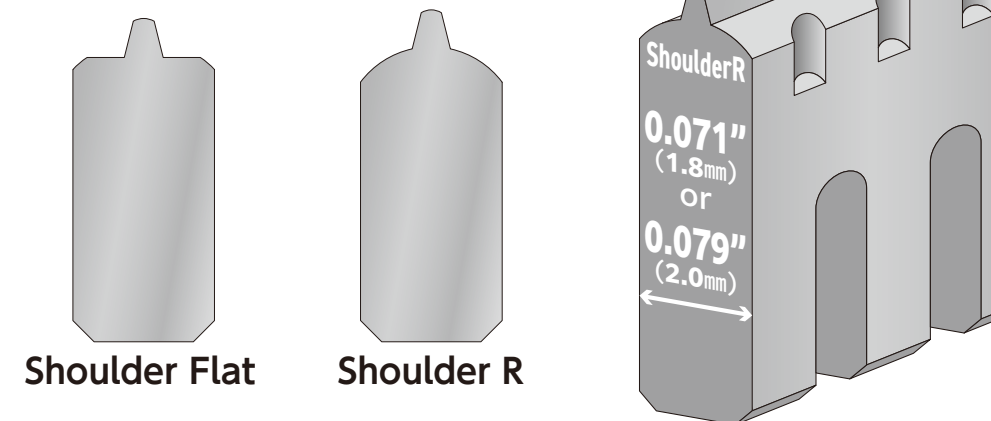



# Punch

## NC punch

### Ejection type



### Ejection type

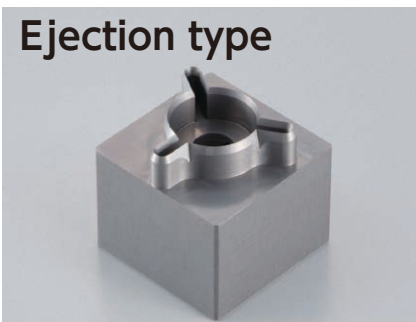

### Side type



[Standard spec]

#### Ejection type

Hardness	HRC52~53/58~59
Blade height	3.0mm
Thickness	0.7mm
Bevel angle	30°/40°
Pin hole	$\phi 0.8 \leq$
Screw hole	M3 $\leq$
Min. line gap	1.4mm
Min. radius	0.1R

#### Feed through type

Hardness	HRC52~53/58~59
Blade height	2.0~4.5mm
Thickness	0.7~1.8mm
Bevel angle	30°/40°/50°
Base	Slit process available
Min. line gap	1.0mm
Min. radius	Side-feed through: 0.5R Joint : 0.1R

## Feed through punch

Diameter (mm)	Height (mm)	Hardness(Hs)
1.0~30.0	23.60	70

- Diameters up to 19.5 mm in increments of 0.5 mm.
- Diameters over 20 mm in increments of 1.0 mm.

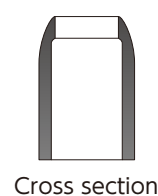

## Side punch

Diameter (mm)	Height (mm)	Hardness(Hs)
1.0~12.0	23.60	70

- Increments of 0.5mm.

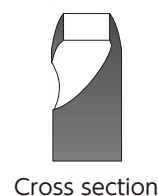

## G-SHOT

Edge profile	Diameter(mm)	Height(mm)	Hardness(Hs)	Thickness(mm)
Tube punch G-Shot	2.0~30.0	23.60	82	0.7
Spring punch G-Shot	2.0~13.0	23.60	82	0.7
Side punch G-Shot	1.5~12.0	23.60	82	

- OD = Diameter of edge + 0.7mm (thickness 0.7mm)
- G-Shot has extremely high sharpness and high accuracy by mirror finishing
- Can be created at 0.1mm intervals
- Feed through punch, Label punch and WG can also be created
- Please contact us about other specs, stock and etc
- There is also an exclusive catalog



## Tube punch PLUS

Diameter (mm)	Height (mm)	Hardness (Hs)	Thickness	Remarks
2.0~7.0	23.60	73	0.7	Non through type
3.0~30	23.60	73	0.7	

- OD = Diameter + 0.7mm (thickness 0.7mm)
- "PLUS" is a product with ground edge finished process
- Increments of 0.1mm.
- Contact us for other specifications and stock confirmation.

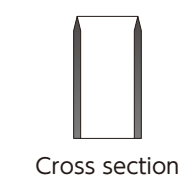

## Tube punch

Diameter (mm)	Height (mm)	Hardness (Hs)	Thickness	Remarks
2.0 · 2.5	23.60	70	1.0	Non through type
3.0~30	23.60	70	1.0	

- OD = Diameter + 1.0mm (thickness 1.0mm)
- Increments of 0.1mm.
- Contact us for other specifications and stock confirmation.

## Label punch

Diameter (mm)	Height (mm)	Hardness (Hs)	Thickness
2.0~15.0	6.0	70	0.5
2.0~15.0	7.0	70	0.5
2.0~15.0	8.0	70	0.5
2.0~15.0	9.5	70	0.5
2.0~15.0	10.5	70	0.5
2.0~15.0	12.0	70	0.5

- OD = Diameter + 0.5mm
- Contact us for other specifications and stock confirmation.



## Bended punch

Diameter (mm)	Height (mm)	Hardness (Hs)	Thickness
3.0~30.0	23.60	68	0.7

- OD = Diameter + 0.7mm
- Increments of 0.5mm.

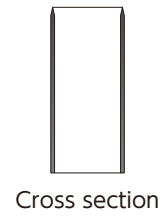

## Welded punch

Diameter (mm)	Height (mm)	Hardness (Hs)	Thickness
3.0~40.0	23.60	68	0.7

- OD = Diameter + 0.7mm
- Increments of 0.5mm.

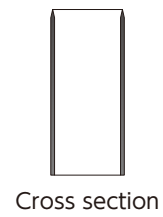

## Spring punch

Diameter (mm)	Height (mm)	Hardness (Hs)
1.0~15.0	23.60	78

- Increments of 0.5mm.



## Pointed punch

Diameter (mm)	Body diameter (mm)	Height (mm)	Hardness (Hs)
0	2.0	23.60	70
0	2.5		
0	3.0		
0.5	2.5		
0.5	3.0		
1.0	2.0		
1.0	2.5		
1.0	3.0		
2.0	2.5		
2.0	3.0		



## Cup pointed punch

Diameter (mm)	Body diameter (mm)	Height (mm)	Hardness (Hs)
1.0	2.0	23.60	70
1.0	2.5		
1.0	3.0		
1.5	2.5		
1.5	3.0		
2.0	2.5		
2.0	3.0		
2.5	3.0		

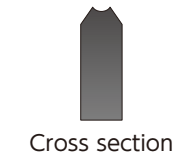

## Cup punch

Diameter (mm)	Height (mm)	Hardness (Hs)
2.0~7.0	23.60	70

- Increments of 1.0mm.



## RDC-FB type

Effective range (mm)	Body size (mm)	Weight
A3 297×420	710×726×252	72kg
A4 210×297	467×418×195.5	35kg
A5 148×210	380×356×190.5	25kg
A6 105×148	318×313×185.5	14kg

- Do it on the tabletop simply.
- Adjust the height easily.
- Combined use of Steel cutting rule die and Pinnacle die.

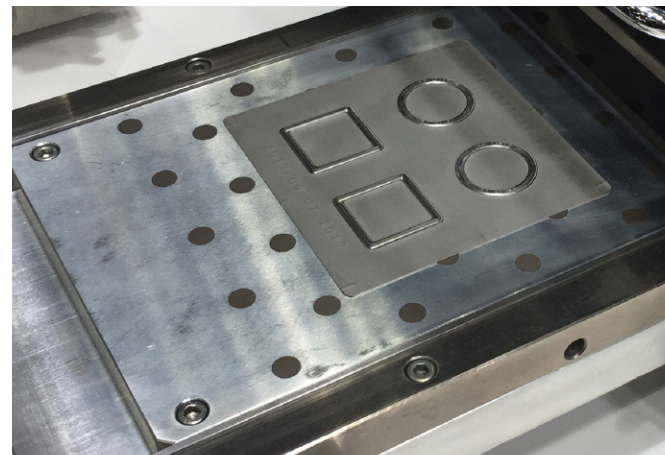
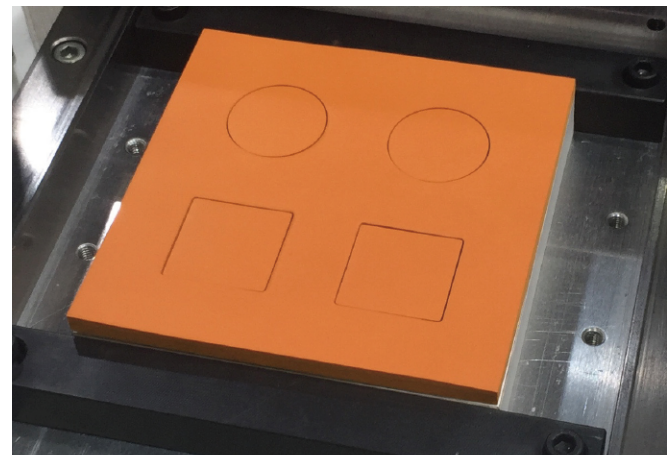
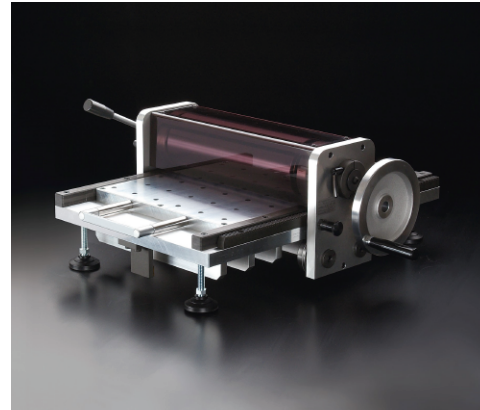

### Case of steel cutting rule die : How to set up and the cutting process



Remove the screws to take the magnetic plate off



Place the die and adjust the ditch with fitting screws and the clearance control jack

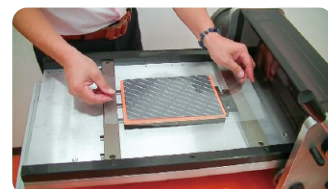

Place a material and dummy film on the die and then turn handle



Completed the kiss cut and full cut

### Case of Pinnacle die : How to set up and the cutting process



Use the screws to place the magnetic plate on

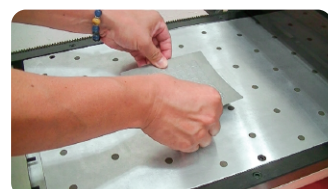

Confirm all clear on the top and place the die on



Place a material then turn the handle

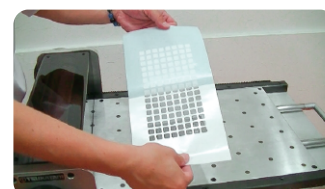

Completed the kiss cut and full cut

※Easy to adjust the height with Dial scale

## Specifications & Technical information

### Base material

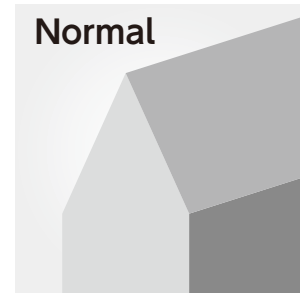

The entire cross section of the blade is made from homogeneous steel.

Code : S·MH·H·HH

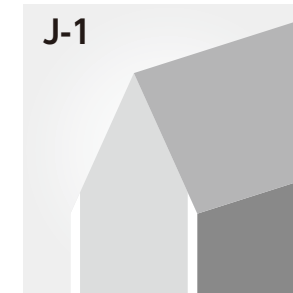

The surface layer of cross section of the blade is made of decarburized steel, providing excellent bending workability and elastic strength.

Code : DS·DMHE·DMH·DH

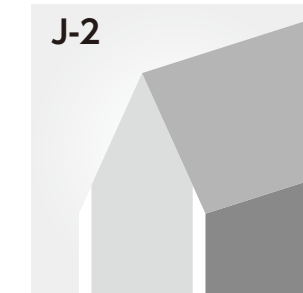

The surface layer of cross section of the blade is made of deeply decarburized steel, creating more elastic bending workability.

Code : SF·MHF·HF

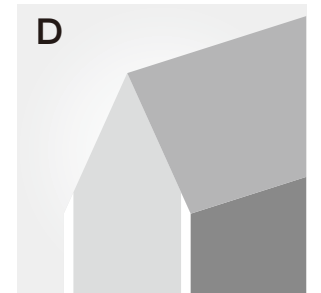

This steel is transformed to martensite steel by applying special heat treatment to the J-1 material. This is a kind of steel with a white, beautiful surface.

Code : D40·D45·D50·D60

### Body hardness and Edge hardness

Steel is heat-treated to provide strength. The bodies and edges are available in hardness ranging from the soft type to the hard type to respond to extensive requirements for bending workability and durability. Hardening treatment is applied to edges to increase their durability. Since the hardening treatment makes only the edges further harder, durability is increased even for products with soft body.

Example : DS-70, D45-75

#### Body hardness

Normal	J-1	J-2	D	Hardness
-	-	-	D40	HV270
S	DS	SF	D45	HV300~325
-	DMHE	-	D50	HV360
MH	DMH	MHF	-	HV390
H	DH	HF	D60	HV450
65	-	-	-	HV490

#### Edge hardness

Code	Hardness
70	HV550
75	HV620
80B	HV620 (0.20depth)
80	HV670 (0.25depth)

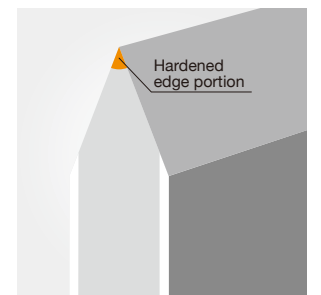

- t=0.7mm h=23.6~23.8mm

### Edge profile and Height

Standard profile specifications include center bevel, center double bevel and side bevel. The edges of the TSUKATANI Steel Cutting rules are finished to sharp profiles by micro grinding and also subjected to height control using a precision measuring machine. Any other profiles and height than the standard specifications are also available upon request.

### Back profile

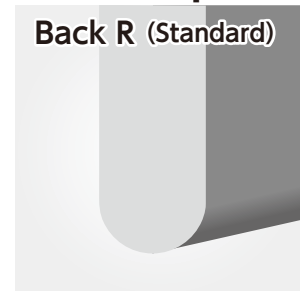

The back is processed to a round profile, which is effective in preventing the bevel from expanding outward when bending the bevel.

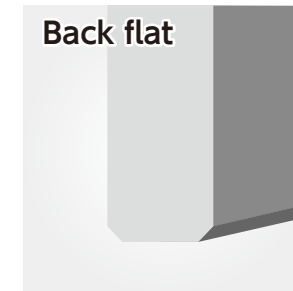

Each corner is slightly chamfered. This profile facilitates checking for the bevel mounting conditions from the back of the cutting die.

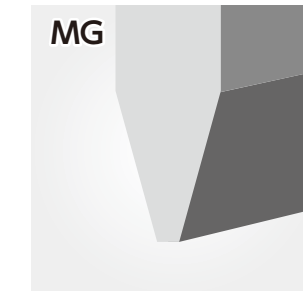

The back is processed to an acute-angled profile. This profile most readily fits to the back plate.



# Packaging & Conversion tables

## Packaging

### Coil

Coil size		(mm)		
Diameter	Code	A	B	C
ID		270	350	465
OD (t = 0.7)		400	460	560

### Winding direction

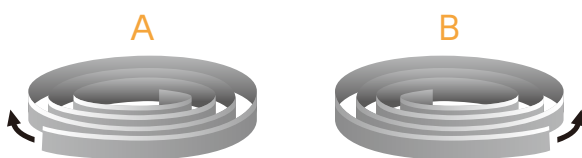

### Package size

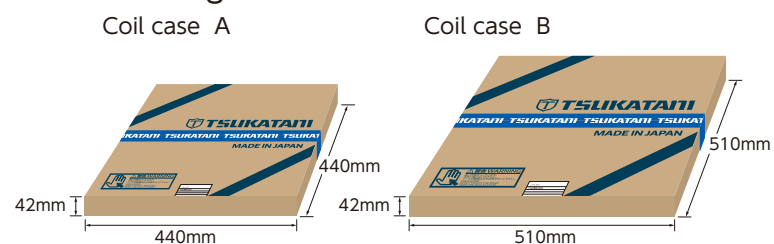

## Conversion tables

Thickness		Length		Height · Width · Depth				Hardness							
mm	pt	mm	ft	mm	inch	mm	inch	mm	inch	HV	HRC	HS	HV	HRC	HS
0.45	1.28	610	2.0	0.10	0.004	5.00	0.197	23.44	0.923	210	-	30	720	61.0	83
0.53	1.50	915	3.0	0.15	0.006	5.20	0.205	23.45	0.923	230	-	33	740	61.8	84
0.71	2.01	1000	3.3	0.20	0.008	6.00	0.236	23.50	0.925	250	22.2	36	760	62.5	86
0.90	2.55	1220	4.0	0.23	0.009	7.00	0.276	23.60	0.929	270	25.6	38	780	63.3	87
1.00	2.83	2000	6.6	0.28	0.011	8.00	0.315	23.65	0.931	290	28.5	41			
1.07	3.03			0.35	0.014	9.00	0.354	23.80	0.937	300	29.8	42			
1.20	3.40			0.50	0.020	9.50	0.374	24.10	0.949	320	32.2	45			
1.40	3.97			0.70	0.028	10.00	0.394	24.40	0.961	340	34.4	47			
1.42	4.03			0.80	0.031	10.50	0.413	25.00	0.984	360	36.6	50			
1.50	4.25	m	ft	0.90	0.035	12.00	0.472	29.00	1.142	380	38.8	52			
1.80	5.10	30	98.4	1.00	0.039	13.00	0.512	30.00	1.181	400	40.8	55			
2.00	5.67	50	164.0	1.20	0.047	15.00	0.591	32.00	1.260	420	42.7	57			
3.00	8.50	70	229.7	1.30	0.051	20.00	0.787	35.00	1.378	440	44.5	59			
		100	328.1	1.50	0.059	21.00	0.827	40.00	1.575	460	46.1	62			
				1.60	0.063	21.60	0.850	45.00	1.772	480	47.7	64			
				1.70	0.067	22.00	0.866	50.00	1.969	500	49.1	66			
				2.00	0.079	22.30	0.878	55.00	2.165	520	50.5	67			
				2.20	0.087	22.40	0.882	60.00	2.362	540	51.7	69			
				2.50	0.098	22.60	0.890	65.00	2.559	560	53.0	71			
				2.60	0.102	22.85	0.900	70.00	2.756	580	54.1	72			
				2.80	0.110	22.90	0.902	75.00	2.953	600	55.2	74			
				3.00	0.118	23.00	0.906	80.00	3.150	620	56.3	75			
				3.30	0.130	23.10	0.909	90.00	3.543	640	57.3	77			
				4.00	0.157	23.20	0.913	100.00	3.937	660	58.3	79			
				4.20	0.165	23.30	0.917			670	59.2	80			
				4.40	0.173	23.40	0.921			700	60.1	81			

# CT type

## CT-2 Straight Cutter / CT-3 Straight Cutter / CT-5 Lipper

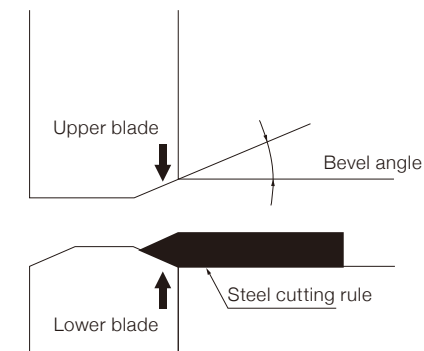

(CT-2 Cutting position)

- Used to cut cutting rules. (CT-3 has no base)

## CT-6 Straight Cutter / CT-7 Lipper (LR type)

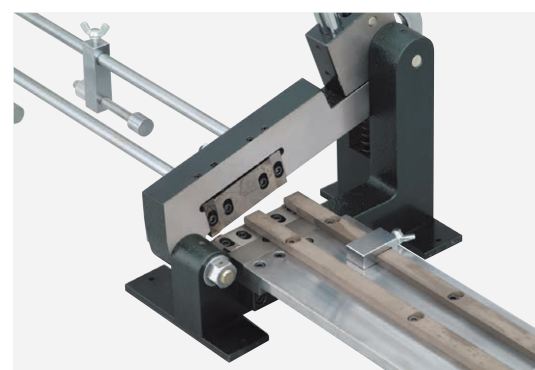

Possible to cut after bending

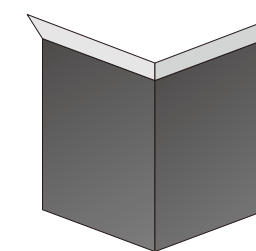

- A single straight cutter / lipper enables both rightward and leftward cutting.
- Cutting with a back guide is enabled.

## CT-8 Notcher



- Used to process the bridge portion
- Adjustment of bridge depth is made with a single motion, just by turning the dial.
- Small / Large type
- Standard groove 9mm

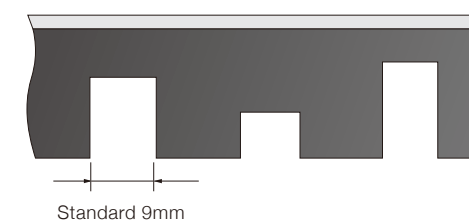

## CT-9 Straight cutter / CT-10 Lipper / CT-11 Notcher (Dual type)

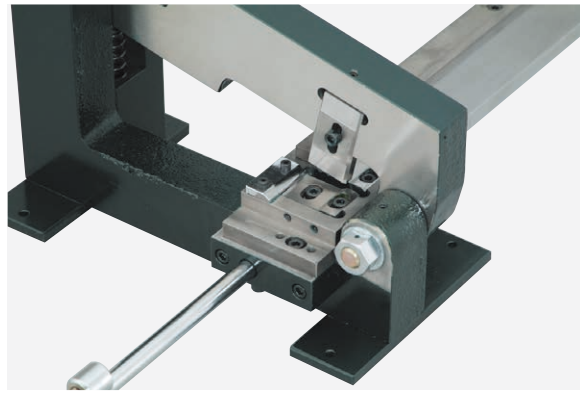

- A single operation makes it possible to cut each side of material. This type is best suited to cut materials to the same size in large batches.
- The notcher with cutting function is designed for the standard cutting width of 6 mm. (The machine for cutting length ranging from 3 to 5 mm is also available upon request.)

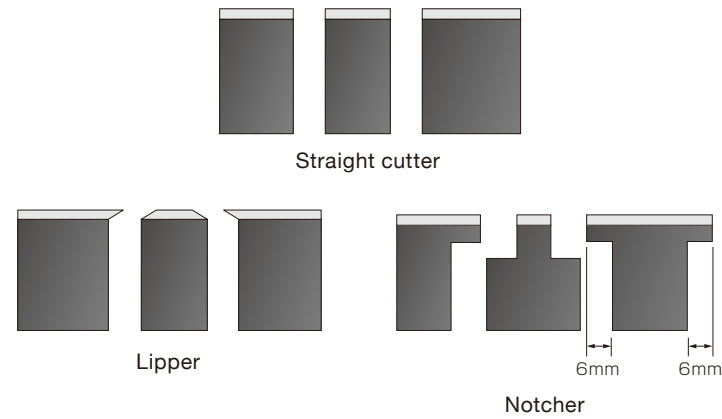

### Slide type table of straight cutter

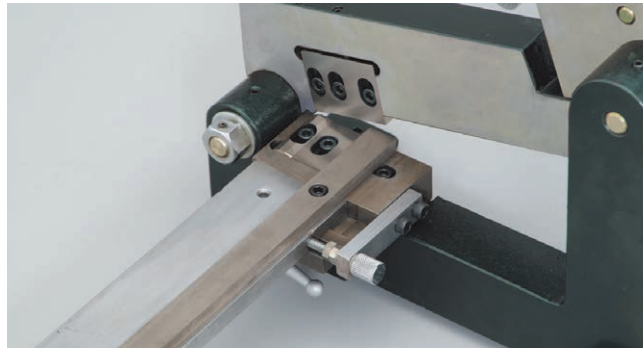

- The table of straight cutter can be changed to the slide type.
- Easy adjustment of cutting position is made just by turning the dial.
- Adaptable to knife height of 32 mm at maximum
- Adaptable to CT-2, CT-5, CT-6, CT-7, CT-9, and CT-10

### Size of straight cutter

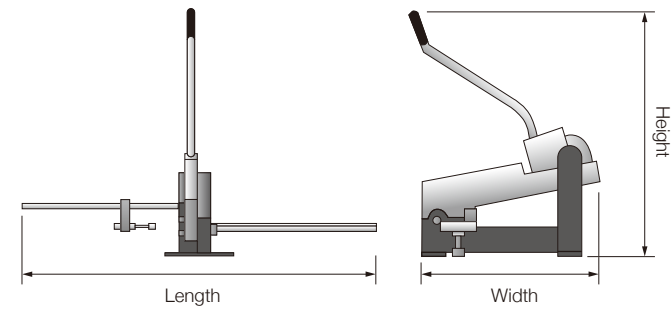

Size  
Length 975 × Width 305 × Height 750 mm

## CT-20 Straight cutter / CT-21 Lipper / CT-22 Notcher (New type)

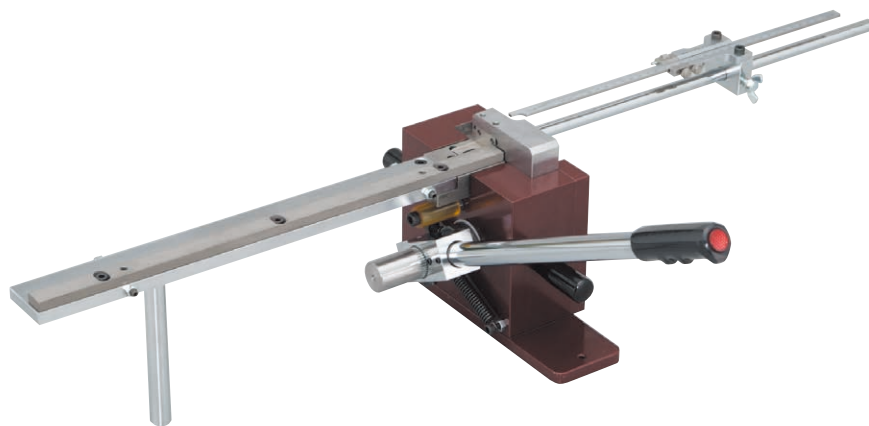

Size  
Length 970 × Width 310 × Height 210 mm

- Compact cutting section. cutting is easy after bending.
- Dual straight cutter is available. (CT-23 · CT-24)

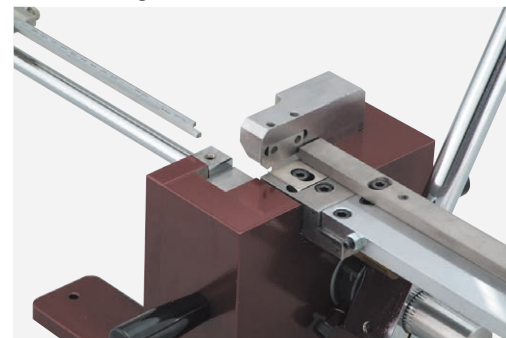

## EP type

The EP type is optional equipment that can be mounted to CT series (Straight cutters) and BD series (Benders).

### EP-1 Slide scale for Straight cutter



- Micrometer spec
- Option for CT-2·CT-3·CT-5·CT-6·CT-7

### EP-2 Slide scale for label bender

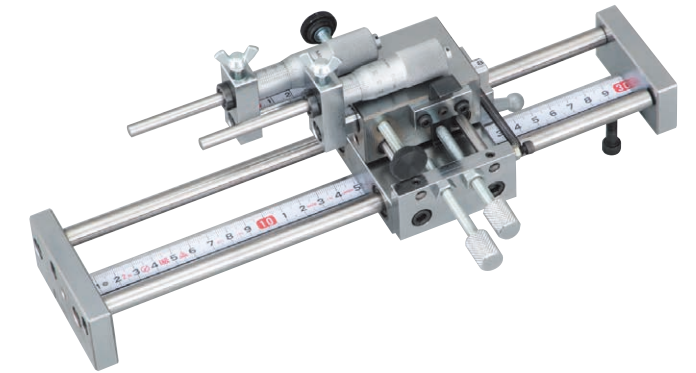

- Micrometer spec
- Option for BD-6

### EP-3 Slide scale for bender



- Micrometer spec
- Option for BD-5

### EP-4 Slide scale for bender

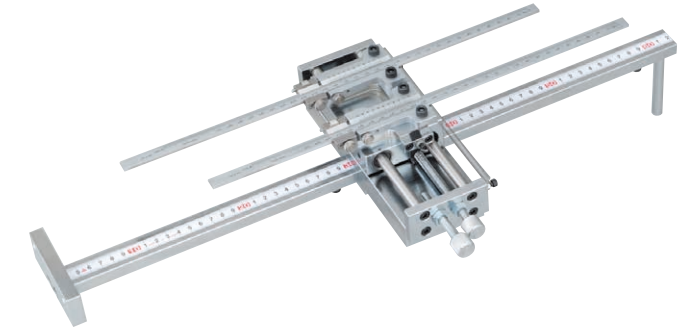

- Slide calipers spec
- Option for BD-5

### EP-5 Digital slide calipers for Straight cutter

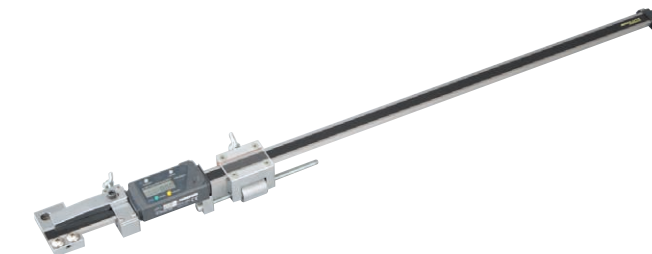

- For 600mm, 1000mm
- Option for CT-9·CT-10·CT-11



# BD type

## BD-5 Standard bender

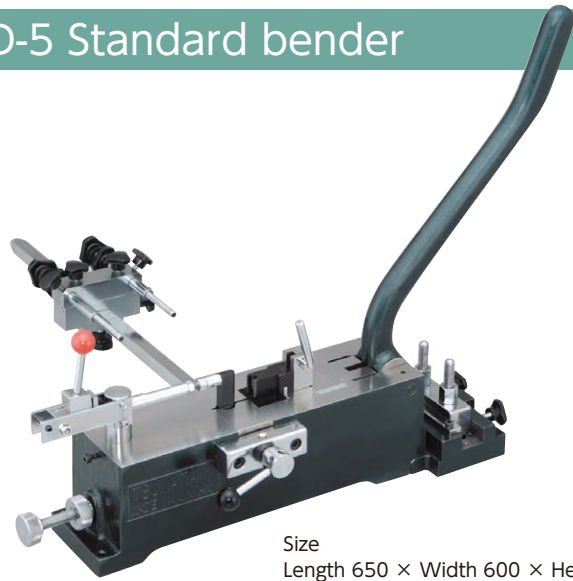

Size  
Length 650 × Width 600 × Height 510 mm

- Moving stroke adjustment can be made with a single motion in two-stroke steps.
- Male stopper is one touch type.
- 36 pcs. of standard dies

### Options



- Width : 3mm·4mm·5mm·7mm·9mm
- Edge R and Sword TIP (Standard 3×7mm) available

### BD-5 Dies size list

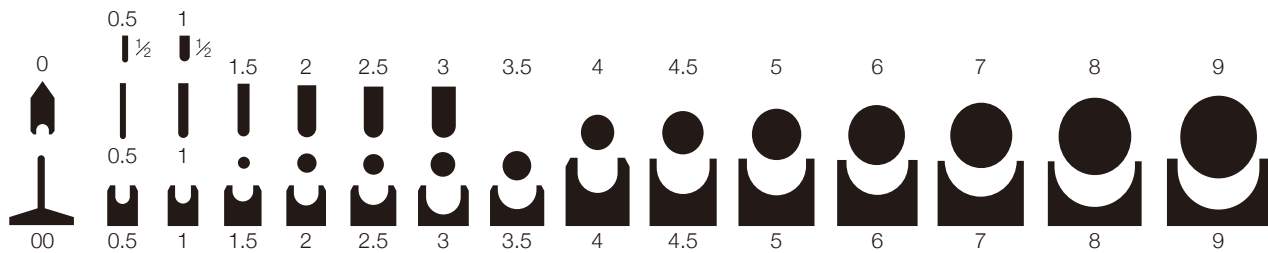

## BD-6 Label bender



Size  
Length 370 × Width 430 × Height 400 mm

- Both bending and cutting equipped
- Male stopper is one touch type.
- Straight cutter or lipper is selectable.

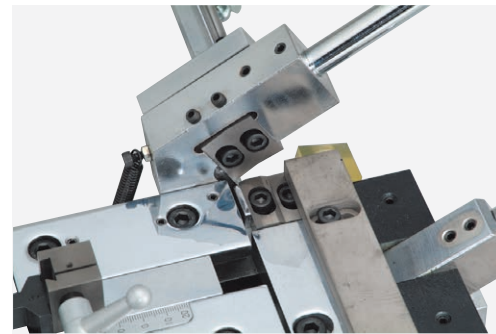

### BD-6 Dies size list

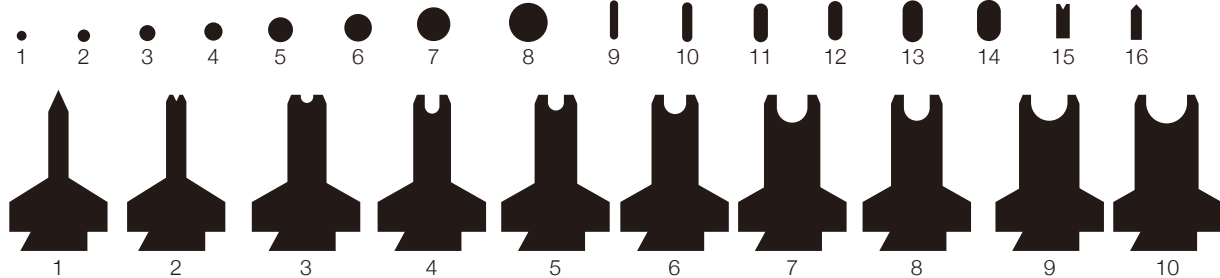

To the world with unique advanced technologies and know-how cultivated with the traditions



## WORLD WIDE NETWORK



TSUKATANI is a leading manufacturer of business-form cutting tools, steel cutting rules and pinnacle dies, which are known as the Cutting Edges (special cutting tools for industrial use) out of several tens of manufacturers existing in the world. In Japan, TSUKATANI has 90% of the market share in the business-form cutting tools, 60% of that in the steel cutting rules used to die cut cardboards and paper packages, and 70% of that in the pinnacle dies. Through research, development, manufacturing and marketing and

sales of these Three Cutting Edges, TSUKATANI is expanding the possibilities for cutting. As to overseas business, TSUKATANI has entered into technical collaboration with overseas manufacturers not only to work on cooperation, but also to actively promote exchanges of information and expansion of networks with them. In addition, TSUKATANI has so far exported its products to 31 countries in Asia, Americas, Europe, and Oceania and been expanding business on a global scale.

### Some history on Tsukatani

Since our establishment in 1951, Tsukatani has been satisfying the needs of the times, such as small-quantity, high-variety small-lot production and quick deliveries, while making an exhaustive study of the quality of "cutting" and "punching". Under the severe business environment of Japan's economic recession and the intense catching-up of Asia-based manufacturers headed by China, how to grow into a company that further unites technological superiority and competitive pricing is a big assignment for Tsukatani. It is our great pleasure to tell you that a series of exciting changes have brightened our prospects; for example,

demand for PINNACLE DIE, a pillar of our third business domain, has been rapidly increasing, our products have started being applied to the "cutting" and "punching" of printed circuit boards, liquid crystals, and other electronic components, and the Asian market is rapidly expanding. It would be a rational choice for us to concentrate our management resources in these growing fields in the future. To achieve this, without resting on our proprietary technologies and original distribution network, we are ready to aggressively take on cross-border alliances, if we can find worthy technologies and advantageous cooperative conditions.