



THE PERFECT COMBINATION

# ***FLEXIBLE PINNACLE DIE***<sup>®</sup>

## ***NP PINNACLE***<sup>®</sup>

■ Maximum edge height 3.0mm



 **TSUKATANI**

# THE PERFECT COMBINATION

# ***FLEXIBLE PINNACLE DIE***®



● Window envelope

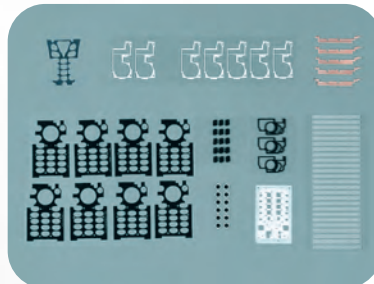

● Precision processing material and name plate

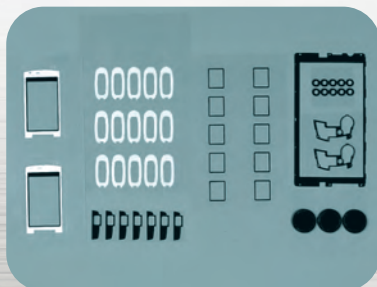

● Packing material and cushion material



● Double-sided adhesive tape

## **FLEXIBLE PINNACLE DIE**

Pinnacle Die with the protrusion (cutting edge) finished sharp. This is used by wrapping around a magnetic cylinder.

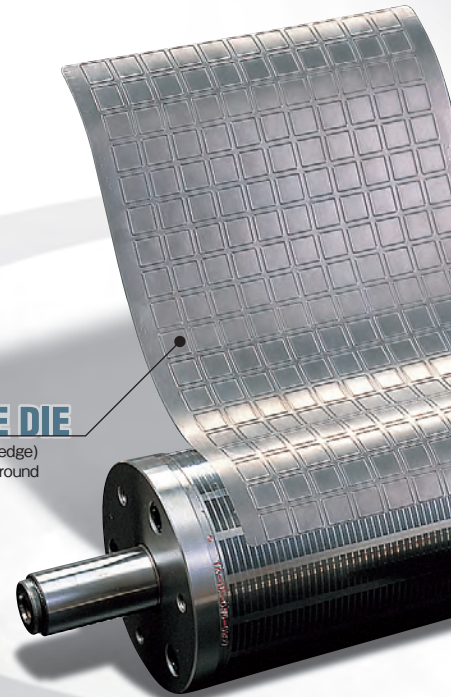

## ■ Peripheral equipment

### Unit for magnetic cylinder (RDC RB type)

- It is recommended to use Tsukatani magnetic cylinder to enable the pinnacle die to exhibit its superb cutting quality to the maximum.
- All Tsukatani's units are designed to fix corner metals to achieve the stable punching.
- The anvil roll (reception barrel) is hardened and hard chrome plated to minimize scratches on the surface.
- Various specifications can be designed and manufactured.
- 500-kg and 1500-kg digital display load cells are able to be installed.

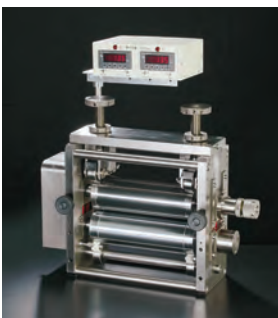

### Load cells (500kg / 1500kg)

- Digital display when sensor reacts to force.
- Available as a reference to adjust the pressure balance of operation side and gear side when mounting a die.
- 2 types (500kg and 1500kg).



### Upper and Lower magnetic cylinder unit (Embossing)

- Use magnetic cylinder with upper and lower location pin.
- After matching location, set upper and lower die for each cylinders ; setup is complete.
- Embossing amount is decided by thickness of material and clearance between upper and lower die.



# Flexible Pinnacle Die achieves various designs.

"Flexible Pinnacle Die" is a product of Tsukatani Hamono Mfg. Co., Ltd.

"Tsukatani" Flexible Pinnacle Die cuts and dies very effectively because of its sharp cutting edge. It's really an excellent tool! Customers in the die cutting industry really love the performance of our products, and the proven track record gives self-confidence to our staff members.

Further, our continued efforts toward improving quality have achieved a wider range of product applications.



● Stickers and labels

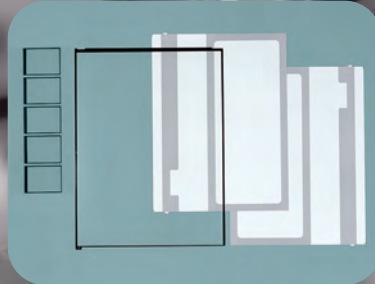

● Reflection and diffusion sheets and light-shielding tape

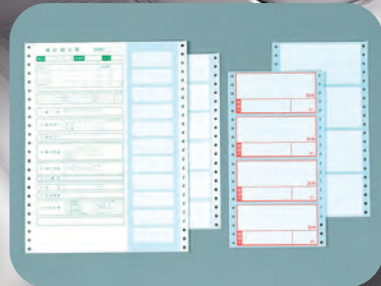

● Tucked form

## MAGNETIC CYLINDER

Magnetic cylinder the pinnacle die is wrapped around. Displacement is prevented by strong magnetic force (2200 gauss). The bearing is hardened by Tsukatani's original method.

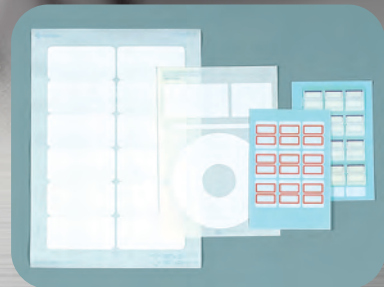

● Page printer

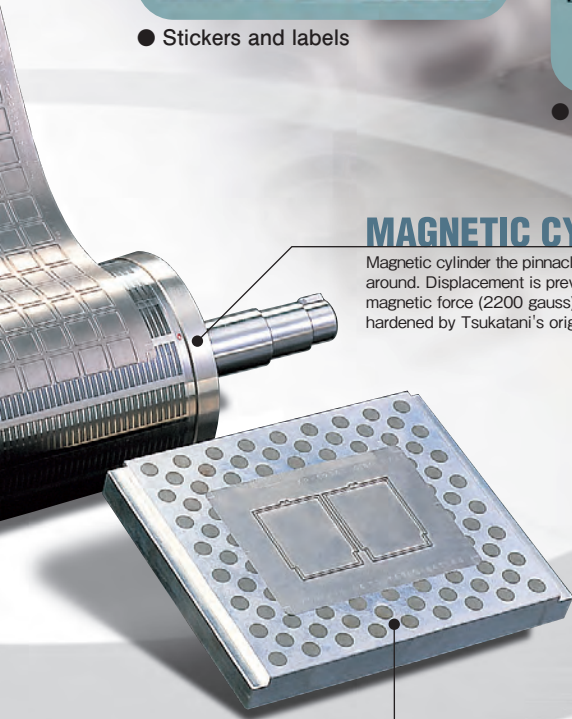

## MAGNETIC PLATE

Magnetic plate made of hard aluminum that powerfully fixes the pinnacle die. The high-precision plate improves the cutting quality of pinnacle die.

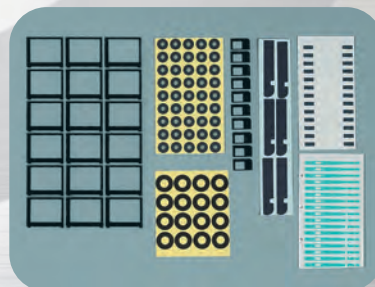

● Insulator

### Simplified punching machine (RDC FB type)

- Test-punching is easily performed on a table.
- Height is easily adjusted.
- Both pinnacle die and conventional cutting die can be used.
- Effective range to punch paper (machine proper size: mm)
  - A3 type (710×726×252 72kg)
  - A4 type (467×418×195.5 35kg)
  - A5 type (380×356×190.5 25kg)
  - A6 type (318×313×185.5 14kg)

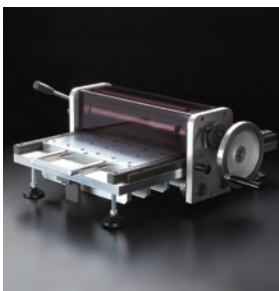

### Magnetic cylinder

- A strong 2200 Gauss magnet positively secures the pinnacle dies.
- Scratch-resistant journal by quench hardening
- Bearer replaceable structure cylinder
- Pre-processed gears (50 to 154) are available for label printers.
- Max. cylinder size: 1,500mm(L) × 250mm(Dia); surface length: 950 mm; Max. load: 200 kg
- Feel free to contact us for your special requirement specs.



### Magnetic plate & aluminum plate

- Magnetic plate and aluminum plate are made from hard aluminum, which render themselves resistant to impact. For flat die cutting, the magnetic plate is recommended to ensure easy setting.
- Parallel ground magnetic plate assures the cutting ability of the pinnacle die whose edge height is finished to an accuracy of  $\pm 0.003$  mm ( $\pm 0.005$  mm).
- Thickness of 7mm to 24mm are supported. [Max. size: 250mm×250mm for 8mm and 350mm×350mm for 24mm]
- We are ready to design and manufacture different specifications such as label printer, press and other machines.

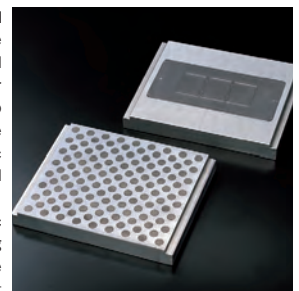

THE PERFECT COMBINATION

# FLEXIBLE PINNACLE DIE®

## NP PINNACLE®

■ Maximum edge height 3.0mm

### Standard specification of Flexible Pinnacle Die

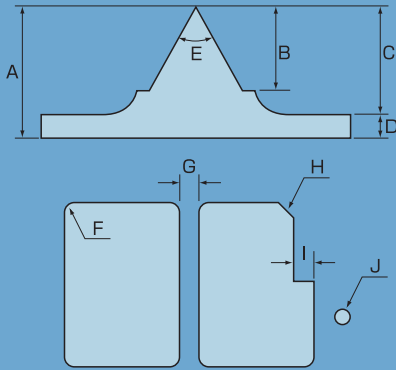

### Standard Hardness: HRC50 (AP)

Units: mm

	For rotary press	For flat die cutting		
A. Edge height	0.35 ~ 0.58	0.6	0.8	1.2
B. Edge depth	0.20 ~ 0.25	0.3	0.4	0.8
C. Etching depth	0.22 ~ 0.45	0.4	0.6	1.0
D. Base thickness	0.13 ~ 0.18	0.2	0.2	0.2
E. Edge angle	40° • 50° • 60° • 80°			

Units: mm

	0.35 ~ 0.58	0.6	0.8	1.2
Edge height	0.35 ~ 0.58	0.6	0.8	1.2
Edge angle	For rotary press (60° edge angle)	For flat die cutting (50° edge angle)		
F. Min. Radius	0.3	0.25	0.3	0.55
G. Min. line gap	0.7	0.6	0.7	1.1
H. Min. C-face	0.2	0.15	0.2	0.35
I. Min. crank	0.2	0.2	0.2	0.2
J. Min. diameter	0.7	0.6	0.7	1.1

### Standard specifications of NP pinnacle die

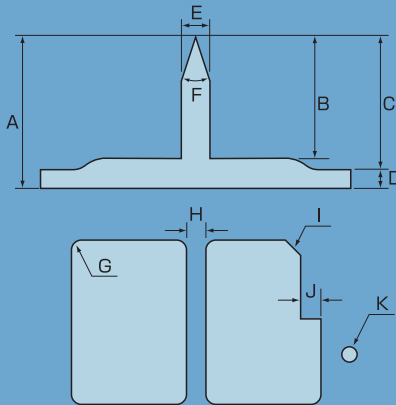

### Standard Hardness: HRC50 (NP)

Units: mm

	For flat die cutting		
A. Edge height	1.2	2.0	3.0
B. Edge depth	0.9	1.3	2.2
C. Etching depth	1.0	1.5	2.4
D. Base thickness	0.2	0.5	0.6
E. Blade thickness	0.3	0.4	0.4
F. Edge angle	30° • 40° • 50° • 60° • 80°		

Units: mm

G. Min. Radius	0.1	0.1	0.1
H. Min. line gap	0.9	1.0	1.2
I. Min. C-face	0.3	0.3	0.3
J. Min. crank	0.2	0.2	0.2
K. Min. diameter	0.9	1.0	1.2

Specifications for 40-degree cutting edge angle

### Determination of Edge height

#### For rotary press

It is the standard setting of the cutting edge height that the tip end of the cutting blade of the Flexible Pinnacle Die is allowed to cut into the separator by 40 to 50% of the thickness. When the separator is 80 micron, 80 micron x 50% = 40 micron cut is obtained. The cutting edge height in such event is 0.47 mm - 0.04 mm (40 micron) = 0.43 mm, which is obtained by subtracting the uncut portion of the separator from 0.47mm, the difference (undercut) between the bearer diameter of magnetic cylinder and the magnet diameter.

Since the edge height varies according to the dimension of the undercut and the separator thickness, please provide us with accurate values.

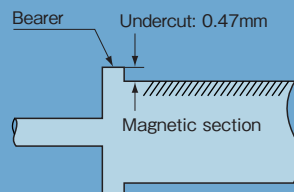

#### For flat die cutting

The plate on which edges are set must be paralleled. For half-cutting, use a steel plate or other hard substance for the mat under the cutting material, but for full cutting, use PVC, PET or other material that will not damage the edge to protect it. In both rotary press and flat die cutting operations, if the surface base material is hard and the separator is soft, it might happen that the surface base material is not cut, but only separator.

#### [Cross section]

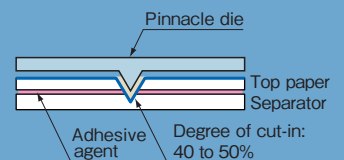

# Special processing (both AP and NP)

## Durability

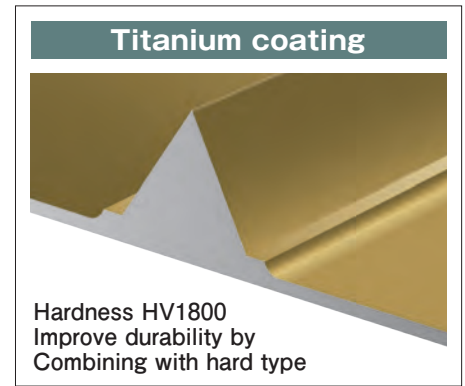
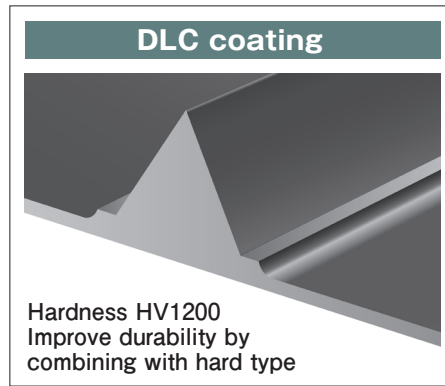
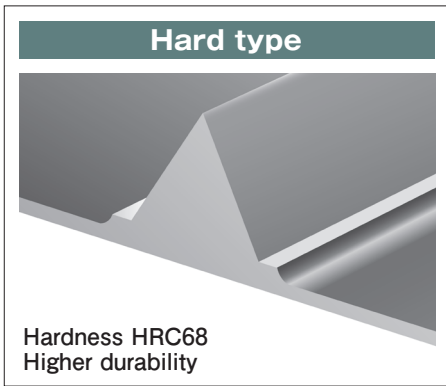

### Comparison table (reference value)

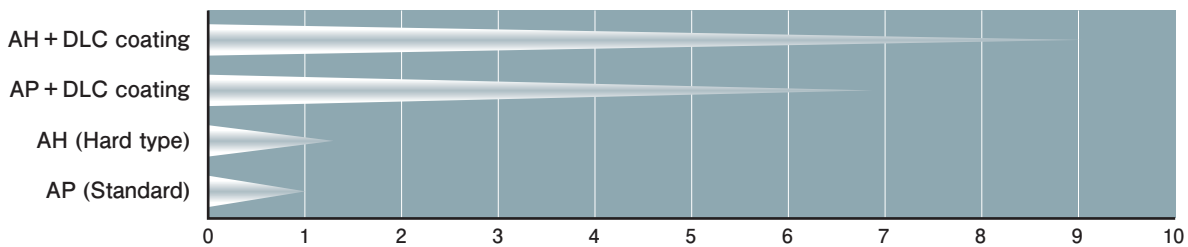

Ratio of durability (set AP=1) ※This is reference of half cutting (Material:PET50S white coat/ Separator:8LB). Not assurance value

Approximate hardness conversion numbers	AP (Standard)	AH (Hard type)	DLC coating (AP/AH)	Titanium coating (AH)
Rockwell hardness (HRC)	50	68	71.5	79.5
Vickers hardness (HV)	510	940	1200	1800

## Measures against glue coating

### TS coating

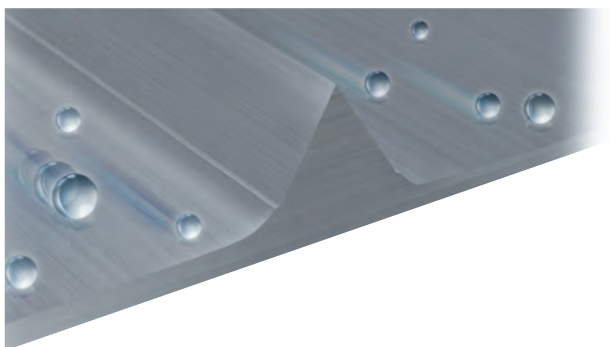

This is super-thin filmy non adhesive coating (monomolecular bond). Unlike conventional coating technology, monomolecular bond realizes superior detachability and slipperiness, and alleviates adhesion of glue and ink. Easy cleaning.

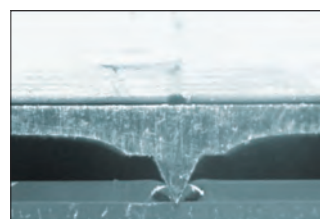
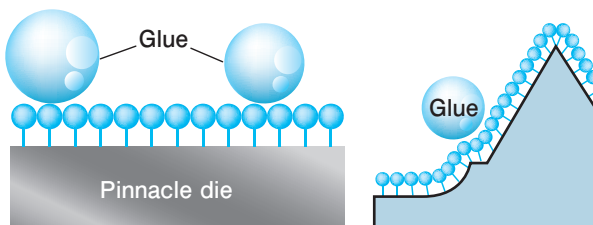

Material: OCA

TS coating

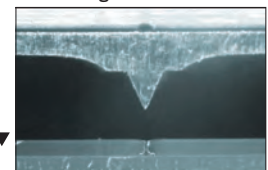

Uncoated

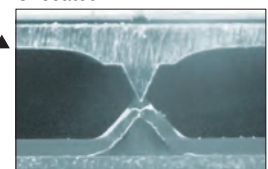

### Different height edges

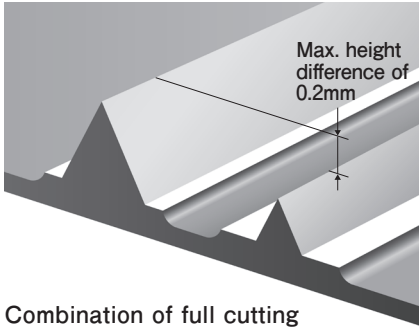

Combination of full cutting and half cutting

### T-Shaped different height edge

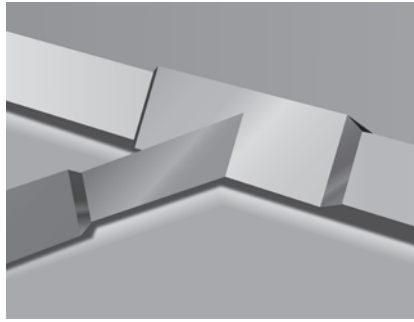

Available at T-shaped parts

### Different height perforation

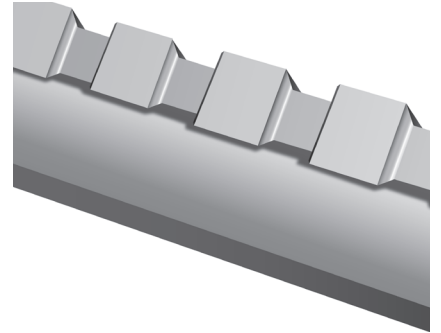

Gap differs depending on material

### Side edge

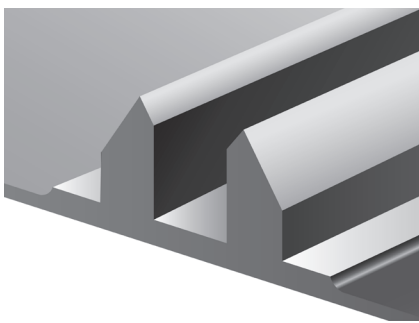

Low cutting resistance

### Side-open edge (SOE)

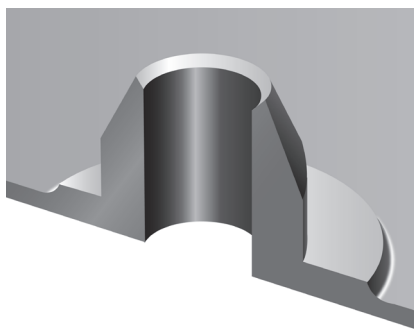

Wire-processed side edge

### Irregular angles edge

Possible to combine five different angles. (15°, 20°, 25°, 30° and 40°)

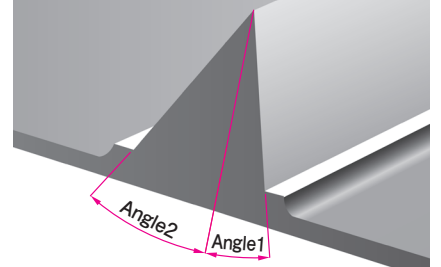

### Micro perforation



4 types of pitches are available.

- CUT0.20 × UNCUT0.15
- CUT0.28 × UNCUT0.23
- CUT0.30 × UNCUT0.20
- CUT0.35 × UNCUT0.15

### Base through-hole

Diameter 2mm or more  
Indispensable for pattern matching and secondary process

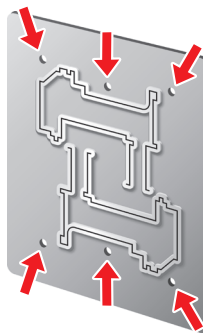

### Pin position



### Wire hole processing

Various shapes can be processed as well as circles.



### Combination of pinnacle dies

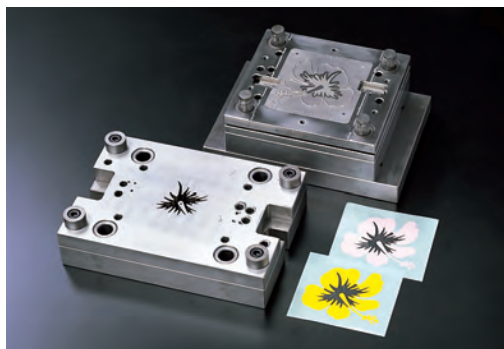

#### Base through-hole and positioning pin or spring pin

Use base through-holes and positioning pins to set a pinnacle die and a plate in parallel, and use the base through-holes and spring pins to keep accurate position during the secondary press.

#### Wire processing pinnacle die and metallic mold

Unite a wire-processed pinnacle die with a metallic mold. Half-cut by pinnacle die and full-cut by male/female metallic mold solve cutting scrap problem.

## Subsidiary Materials for Blade Dies

### Base plate ejection for rotary presses

Ejection using base plate



### Ejection sponge sheet used for flat die-cutting



Sold by the meter.  
Available in 0.8mm, 1.2mm, and 2.0mm thick.

### Spatula used to peel off Pinnacle Die



Used to peel off Pinnacle Die from a magnetic cylinder or a magnetic plate.

## Key points to achieve stable die-cutting

### Rigidity of the magnetic cylinder

Surface length and perimeter of the magnetic cylinder  
A : B = 1 : 1

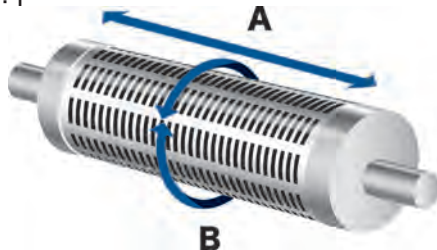

### Rotary press

Essential to eliminate backlash and play and provide rigidity of the unit.

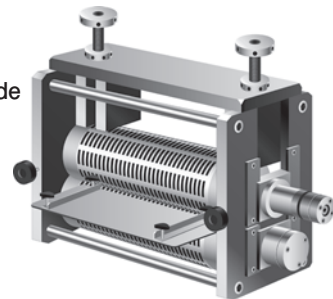

### Platen press

Essential to provide parallelism and rigidity.

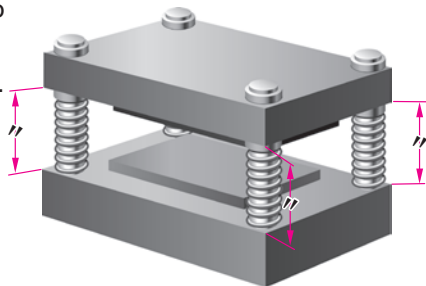

### Precautions for fixing the blade die

Fix the die with tape from the top.

Do not use adhesive or double-coated adhesive tape to fix the die.

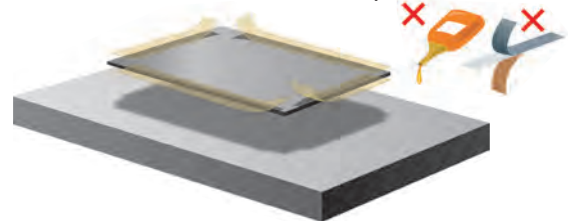

### Precautions for use of the Pinnacle Die, Magnetic Cylinder, and Magnetic Plate

- (1) The Pinnacle Die has a sharp blade edge and base end. To handle the Pinnacle Die, wear personnel protective equipment such as safety gloves for safety.
- (2) The Pinnacle Die has a blade. Carefully handle the Pinnacle Die so as not to cause damage to the blade edge.  
There are a number of iron-made parts around the machine. Cases of damage caused to the blade edge when mounting the Pinnacle Die to a machine have been reported.  
Pay utmost attention to prevent damage to the blade edge.
- (3) The magnetic cylinder and the magnetic plate are now intensely magnetized.  
Do not bring anything that is affected by magnetism, including magnetic cards and watches, close to them.
- (4) Keep the surface of the magnetic cylinder and plate free from deposit at all times.  
Note that metal powder and pieces of metal are easily deposited particularly on the surface of the magnetic cylinder and plate.  
(Deposit can be comparatively easily removed by using adhesive tape.)

### Storage method

- (1) The Pinnacle Die is made of stainless steel. However, it may rust due to various external factors.  
Moistening the Pinnacle Die with palm sweat during work will cause it to rust. Do not store it in places with high temperature and high humidity. Furthermore, apply a coating of antirust oil to it before storing it.
- (2) In order to prevent damage to the blade edge, apply a cushioning material to the blade surface, and then store the Pinnacle Die.
- (3) The Pinnacle Die is an edged tool. Handle it with care similar to that to be paid to general edged tools.

# Order to Delivery process



## How to order the Flexible Pinnacle Die

**1** Fill requirements and fabrication drawing in the thick frame of Flexible Pinnacle Die order sheet and send to Head Office Sales Department by e-mail.

**Order Form for Flexible Pinnacle Die**

Date: (year) (month) (day)

Name of company	① To _____ manufactory		Person in charge	Tsukatani
Control number	② E-00123			
Machine	③ I36	U C	④ 0.47 mm	⑤ LR-25
Top paper	⑥ YUPO	Separator	⑦ 8K	⑧ 80
Edge height	mm	mm	mm	mm
Edge angle	-	-	-	slit
Margins	Top	Bottom	Left	Right
			Cavity	Around
			Across	

( 50 ) ( 3 )  
 ( 60 )  
 ( 3 )  
 × ( 2 ) Cavities  
 R (Radius) ( 3 )  
 ×  
 ( 2 ) Cavities

Sales representative

Hard	D L C	1.2T	2.0T	Wire/SOE	Side edge	1/8inch	Milling	Micro	Tabaped	Date
Transport specified	After quality	Date of shipping	Date of delivery to destination							

⑧  
 TSUKATANI HAMONO Mfg. Co.,Ltd.  
 Head Office Sales Department FAX: +81-72-996-7715 e-mail: anvil@tsukatani-hamono.co.jp

Fill requirements and fabrication drawing in the thick frame of the order sheet and send it by e-mail.

**2** Tsukatani make a drawing according to your order.

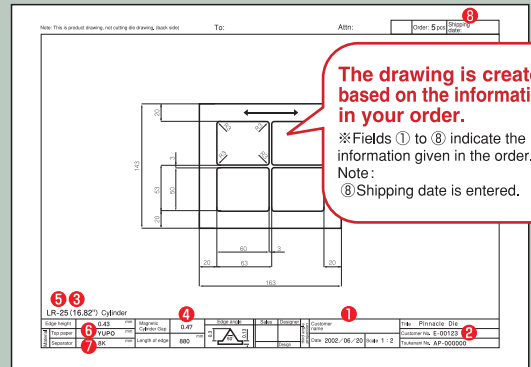

**3** The drawing is sent to you by e-mail. Please check for our mutual confirmation.

**4** Once your confirmation arrives, Tsukatani manufacture your flexible pinnacle die.

Give us directions on the cutting die line by any of the following methods:

- ① CAD data of DXF or DWG type
- ② Data of either EPS or AI formats of Adobe Illustrator
- ③ Dimensional drawing by fax
- ④ Positive film for plate making, art work and punching sample (in the case of positive film for cutting die, about 0.2 mm line width is necessary).

## How to estimate Flexible Pinnacle Die

When drawing is completed on the CAD system, the total edge length (in mm) is indicated on it.

$$\left( \text{Total edge length by CAD} \times \text{Units by Styles A, B and C} + \text{Base rate (unit price by base size categories)} \right) + \text{Special processing rate} = \text{Sales price}$$

<p><b>STYLE A</b></p> <p>Square at four corners</p> <p>Perforation edge              ● Uncut size must be 0.5mm or more              ● For an uncut size of 0.4mm or less, a special estimation will be given.</p>	<p><b>STYLE B</b></p> <p>Right angle</p> <p>Facing up</p>	<p><b>STYLE C</b></p> <p>special estimation</p>	<p><b>Base size categories</b></p> <p>Wide size : 1060mm×850mm (Up to AP1.2t)</p> <p>Full sheet/Largest size: 460mm×610mm (18in×24in)</p> <p>1/2: 1320cm<sup>2</sup></p> <p>1/4: 660cm<sup>2</sup> (A4 paper size)</p> <p>1/8: 330cm<sup>2</sup></p> <p>1/16: 165cm<sup>2</sup></p>
--	---	---	---

Please visit our website for detail.

Tsukatani Hamono

Search



<https://www.tsukatani-hamono.co.jp/>

# TSUKATANI HAMONO Mfg. Co.,Ltd.

Head Office Sales Department 5-30 Kusune-cho, Yao city, Osaka 581-0814  
 TEL: +81-72-996-8774 FAX: +81-72-996-7715  
 e-mail : anvil@tsukatani-hamono.co.jp  
 U R L : <http://www.tsukatani-hamono.co.jp>